



MERGER SERIES
FORAGE
MERGERS



STRONG | EFFICIENT | RELIABLE

HSMFGCO.COM

TF6128 & TF6132

TWIN-FLEX MERIDIAN



MODEL TF6128



FEATURES

- Rubber-mounted teeth
- Heavy 42" wide cross-conveyor
- Exclusive *SOFT-SHOE* suspension technology with in-cab adjust. Self regulating feature that constantly adjust the weight on the skid shoes.
- TF6128 has the narrowest transport width and lowest height in its class.
- TF6132 is ISOBUS ready
- TF6132 has the largest hydraulic system capacity on the market in the 32' class.



LARGE DIAMETER PICK-UP HEADS

All heads are approximately 31" in diameter with an 8" drop to the cross conveyor, allowing for a better release of material to eliminate bunching.



32 MERGER



MODEL TF6132



ONE WING MERGING

The TF6128 & TF6132 mergers have the capability to do one wing merging with either wing in the transport position. Crop discharge can be made to either the left or right.



SMOOTH, CLUMP-FREE WINDROWS

Patented center cam/center drive design provides smooth, clump-free windrows. Merge left, right or split direction.

HYDRAULIC SYSTEM

A 35-gallon reservoir (TF6128) or 65-gallon reservoir (TF6132), coupled with large displacement motors for the pick-up heads and cross conveyor, is able to handle HEAVY crops.

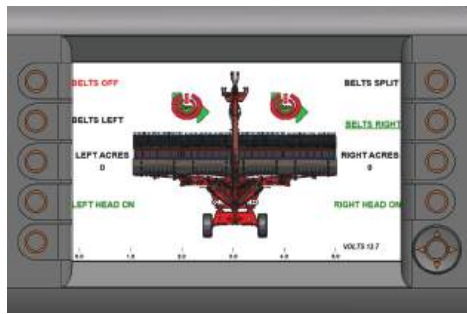

CONTROL BOX FUNCTIONS

The *TWIN-FLEX* merger control box allows you to easily change functions with just the touch of a button.



REMOTE FILTERS (TF6128)

The remote filters are designed to prevent contamination from the tractor entering the merger's hydraulic system.

STEERABLE AXLE & WHEELS (TF6132)



OTHER OPTIONS

Dual drive cross conveyor kit (TF6128)

Hydraulic skid shoe kit (TF6128)

Auto-Lube System (TF6132)

In-cab control box kit for non-isobus tractors (TF6132)

2 POINT HITCH

ISOBUS READY

PATENTED

Center Cam / Center Drive

CROSS CONVEYOR BELT

42" 2-ply cross conveyor belt is the
WIDEST IN THE INDUSTRY!

TEETH

Rubber Mounted

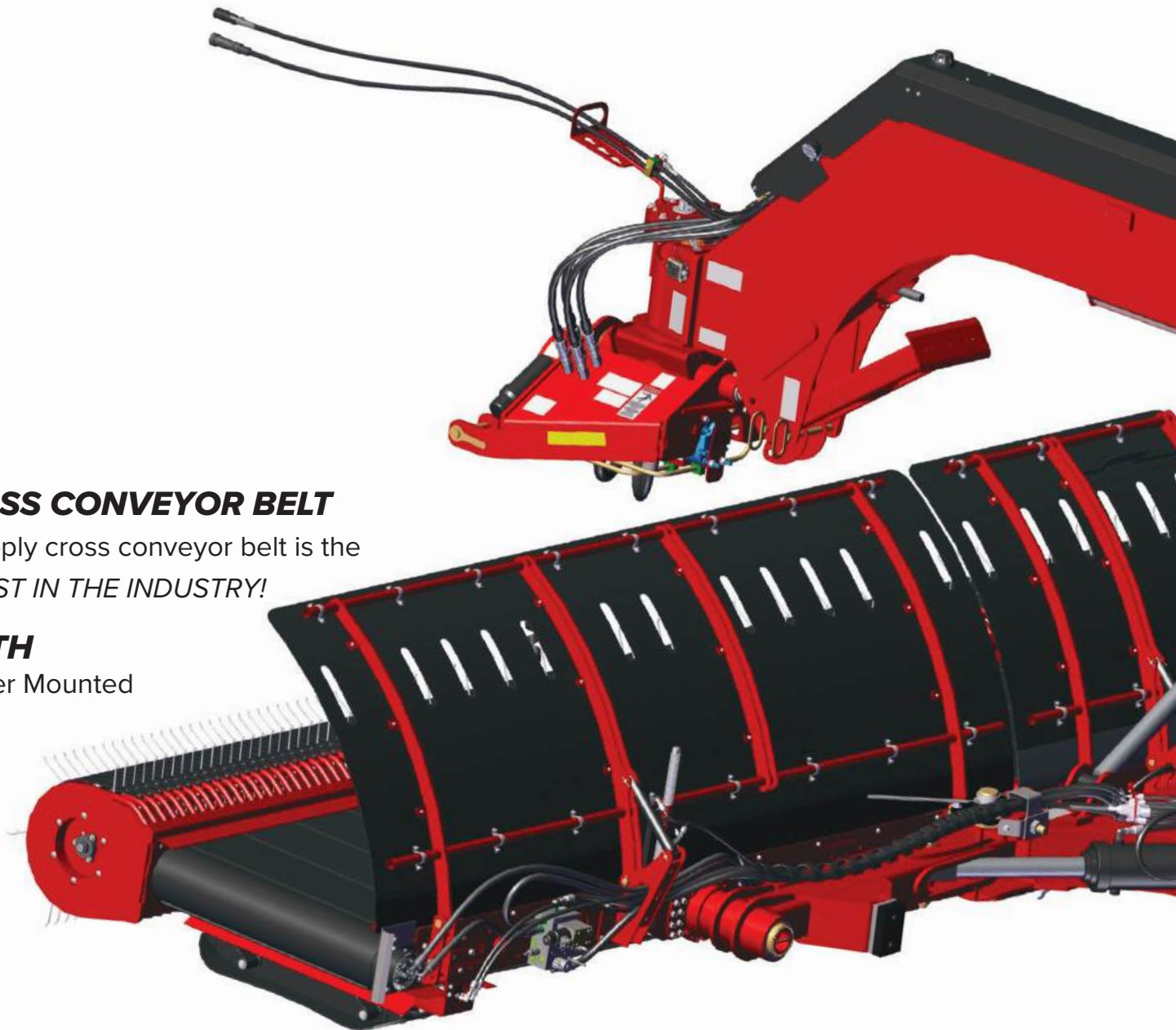

PATENTED SOFT-SHOE

Self contained, self monitoring hydraulic suspension system.
Constantly adjusts head weight. Minimizes skid shoe wear.
Handles all types of field conditions, reduces field damage.
SOFTTEST MERGER HEAD FOOT PRINT IN THE INDUSTRY!

ive System

HYDRAULIC SYSTEM

Fully contained system (no tractor hook ups)

Default mode (belts on)

Head contact protection

ENGINEERED FOR PERFORMANCE.



STEERING AXLE

Rear steering axle (TF6132, UF6136)

Steering position override and shut-off

385/65 X 22.5 16-Ply Agri-Transport Radial Tires

UF613

ULTRA FLEX MERGER



FEATURES

- ISOBUS ready with Aux-N capabilities
- Most head travel in its class, ideal for merging uneven terrains.
- WIDEST cross-conveyor belt in its class at 42".
- Softest merger head foot print in the industry.
- Dual drive cross conveyors
- Electric over hydraulic logic (manual overrides) defaults belts to the right.
- Rubber mounted teeth
- Hydraulic steerable rear axle (patent pending)



TRIPLE HEAD MERGER

Triple-head merger with 36' of continuous working width
heads

36 MERGER



STANDING OUT FROM THE COMPETITION

What sets the ULTRA-FLEX apart from the competition is the capacity it can handle. This merger is designed to handle extreme conditions. It's ideal for the custom operator or large dairy farm making 35' triplemower cuts in extreme terrain that needs to move a lot of material in a short amount of time.

SMOOTH, CLUMP-FREE WINDROWS

Patented center cam/center drive design provides smooth, clump-free windrows.

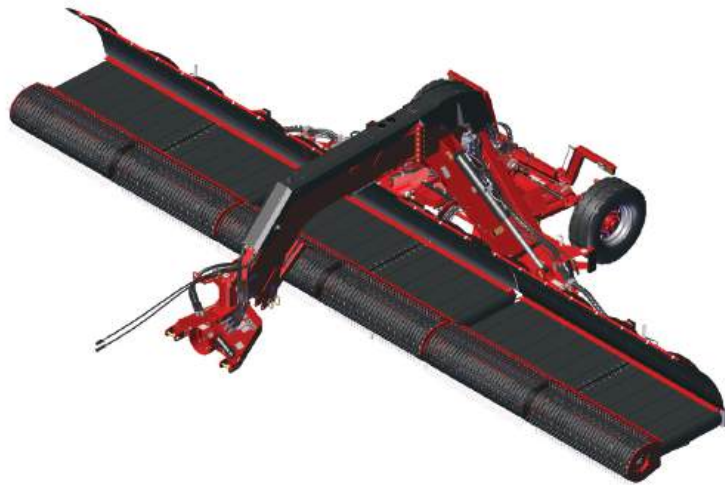

HYDRAULIC MOTORS

High torque rated hydraulic motors for the heads and cross conveyor are the largest in the industry, and coupled with heavy 2-ply cross-conveyor belts, are able to handle heavy crops

HYDRAULIC SYSTEM

Self-contained hydraulic system features a 65-gallon reservoir, no tractor remotes are needed!

ENGINEERED FOR PERFORMANCE

The patented SOFT-SHOE suspension system eliminates field scuff and extends the skid shoe life. Float pressure is adjustable from the operator seat on the fly. The heavy-duty 385/65 x 22.5 radial tires don't scuff in the field!

In-Cab display optional

2-point hitch





	TF6128	TF6132	UF6136
Working width	28' 2"	32'	36'
Transport width	8' 6"	9' 8"	12'
Transport length	25'	24'	24'
Transport height	9' 8"	11' 6"	11' 10"
Pick-up heads	2 (14')	2 (16')	3 (12')
Head travel	20" (10" up & 10" down)	20" (10" up & 10" down)	20" (left & right) & 16" (center)
Pick-up strippers	Poly		
Pick-up teeth	Rubber mounted		
Conveyor belt width	42"		
Cross conveyor on/off/ right/left/split	In-cab / Electric-over-Hyd	ISOBUS Aux N compatible / Opt. non-ISOBUS control box	
Skid shoe height	Manual adjust	Hydraulic (adjustable in-cab)	
Head suspension	Exclusive SOFT-SHOE suspension technology system w/in-cab adjust		
Drive system	3-section high volume pump		4-section high volume pump
PTO	1-3/8" or 1-3/4" 1000 RPM Std.		
Oil reservoir capacity	35 gallons	65 gallons	
Tire size	15R x 19.5 radial	385/65 x 22.5 16-Ply Radial	
Weight	12,260 Lbs.	17,300 Lbs.	21,800 Lbs.
Tractor size	95 HP minimum	150 HP minimum	
Hydraulic requirements	2 sets of remotes (requires closed center hydraulic system) 2750 PSI 12 GPM min.	N/A	
3-point hitch	CAT II, III, or III-N		
Auto default RH merge	Standard		

