



# OPERATOR'S MANUAL

TD1236  
TD1240

Part #93849  
Rev. #02  
HSMFG021825

TD1236 STARTING SERIAL #4ULJB3820SS002060  
TD1240 STARTING SERIAL #4ULJB4229SS003027

# CONTENTS

Warranty . . . . .	1
Manufacturer's Statement . . . . .	2
Warranty Registration Form . . . . .	3
Dealer Pre-Delivery Checklist . . . . .	5
Dealer Delivery Checklist . . . . .	7
Safety Information - Be Alert Symbol . . . . .	9
Explanation of Safety Signs . . . . .	10
Safety Information - Warning - Owner Must Read and Understand . . . . .	11
Cap Screw Torque Values . . . . .	12
Set-Up & Assembly . . . . .	13
Preparing for Operation . . . . .	14
Transporting . . . . .	14
Operation . . . . .	15-16
Adjustments . . . . .	17
Optional Equipment . . . . .	18
Lubrication Guide . . . . .	19
Decal Location . . . . .	20-27
Troubleshooting . . . . .	28
Service Notes . . . . .	29

# H&S WARRANTY

H&S Manufacturing Co., Inc. ("H&S") warrants this product to be free from defect in material and workmanship. Except as noted below, this warranty term is twelve (12) months on labor, and twenty-four (24) months on parts from the date of delivery of the product to the original purchaser by an authorized H&S dealer. Under this warranty, H&S will repair or replace, at its option, any covered part which is found to be defective in material or workmanship during the applicable warranty term. In no case will the covered repair cost of a part or parts exceed the replacement cost of that part. Warranty service must be performed by H&S or a dealer authorized by H&S to sell and/or service the product involved, which will use only new or remanufactured parts or components furnished by H&S. This warranty includes approved parts and labor to fix the product but does not include, and the purchaser is responsible for, any service call and/or transportation of the product to and from the dealer's place of business, for any premium charged for overtime labor requested by the purchaser, and for any service work not directly related to any defect covered under this warranty. This warranty includes only those components of the product manufactured by H&S. Warranty for any component not manufactured by H&S including, but not limited to, engines, batteries, tires, rims, hydraulic motors, pumps, etc. are covered by the warranty, if any, provided separately by their respective manufacturers.

This warranty in all its parts, is extended solely to the original purchaser of the product, is terminated upon any subsequent transfer or sale from or by the original purchaser and extends no third party benefits or rights whatsoever.

The warranty term for any product used in any commercial, custom, for hire or rental application, is limited to six (6) months from the date of delivery of the product to the original purchaser or the first day of service, whichever comes first, by an authorized H&S dealer.

For commercial, custom for hire, or rental application, warranty is limited to 6 months from the date of delivery to the original purchaser, or the first day in service, whichever is earlier.

This warranty does not include:

- (1) Any product that has been altered or modified in ways not approved by H&S;
- (2) Depreciation or damage caused by normal wear, use for which the product was not designed, misuse, improper or insufficient maintenance, improper operation, accident or failure to follow the product Operator's Manual recommendations and product decal recommendations;
- (3) Normal maintenance parts and service;
- (4) Repairs made with parts other than those available from H&S or performed by anyone other than H&S or a dealer authorized by H&S to sell and/or service the product involved.

To secure warranty service the purchaser must report the product defect to a dealer authorized by H&S to sell and/or service the product involved within the applicable warranty term together with evidence of the warranty start date and make the product available to that dealer within a reasonable period of time.

**THERE ARE NO WARRANTIES WHICH EXTEND BEYOND THE DESCRIPTION ON THE FACE OF THIS WARRANTY.** H&S and the companies affiliated with it makes no warranties, representations, or promises, express or implied, as to the performance or freedom from defect of its products other than those set forth above and **NO IMPLIED WARRANTY OF MERCHANTABILITY, FITNESS OR FITNESS FOR A PARTICULAR PURPOSE IS MADE. IN NO EVENT WILL THE DEALER, H&S OR ANY COMPANY AFFILIATED WITH H&S BE LIABLE FOR INCIDENTAL OR CONSEQUENTIAL DAMAGES.** The ONLY REMEDY the purchaser has in connection with the breach of performance of any warranty on H&S products are those set forth above.

The selling dealer has no authority to make any representation or promise on behalf of H&S, or to modify the terms or limitations of this warranty in any way.

11/14/18

## **MANUFACTURER'S STATEMENT**

Your New H&S Product has been manufactured of the finest quality materials and components. The performance you get from your machine is largely dependent upon how well you read and understand this manual and apply this knowledge. There is a right and a wrong way to do everything. Please do not assume that you know how to operate and maintain your Machine before reading this manual carefully. Keep this manual available for ready reference.

H&S reserves the right to make changes or add improvements to its products at any time without incurring any obligation to make such changes to products previously manufactured. Specifications, statements and descriptions of Products contained in this publication are subject to change without prior notification.

## WARRANTY REGISTRATION

- Date of Purchase: \_\_\_\_\_
- Purchaser Name: \_\_\_\_\_
- Street Address: \_\_\_\_\_
- City: \_\_\_\_\_
- State: \_\_\_\_\_ Zip: \_\_\_\_\_
- Phone Number: \_\_\_\_\_
- E-mail Address: \_\_\_\_\_
- Product: \_\_\_\_\_
- Model Number: \_\_\_\_\_
- Serial Number: \_\_\_\_\_
- You have received the Operator's Manual for this product. Yes \_\_\_\_\_ No \_\_\_\_\_
- Interested in receiving the H&S E-mail Newsletter? Yes \_\_\_\_\_ No \_\_\_\_\_

- 
- Dealer Name: \_\_\_\_\_
  - Street Address: \_\_\_\_\_
  - City: \_\_\_\_\_
  - State: \_\_\_\_\_ Zip: \_\_\_\_\_
  - Signature: \_\_\_\_\_

- All fields must be filled out to ensure prompt notification of product and/or warranty updates.

**Please mail the completed WARRANTY REGISTRATION FORM to:  
H&S Manufacturing Co., Inc.  
2608 S. Hume Ave.  
Marshfield, WI 54449**

**Intentionally Left Blank**

# DEALER PRE-DELIVERY CHECKLIST

## AFTER COMPLETION, DEALER SHOULD REMOVE AND RETAIN FOR RECORDS

After the **TOP DOG** has been completely set up, check to be certain it is in correct operating order before delivering to the customer. The following is a list of points to inspect. Check off each item as you have made the proper adjustments and found the item operating satisfactorily.

- TOP DOG** was not damaged in shipment. Check for dents and loose or missing parts. Report damage immediately to H&S Manufacturing Co., Inc.
- TOP DOG** has been correctly assembled according to instructions in this manual. Wheel nuts and all other fasteners are tightly secured.
- All bolts and fasteners are tight.
- All shields and guards are in place and fastened.
- All grease fittings have been lubricated. Both final drive assemblies are at proper gear lube level in site glass. (See Lubrication Chapter in this manual).
- Hoses and fittings are properly attached and there are no visible leaks.
- All mechanisms are operating trouble free.
- Apron chains are adjusted properly.
- Decals are in place and legible.

Model Number \_\_\_\_\_

Serial Number \_\_\_\_\_

Dealer's Name \_\_\_\_\_

Inspection Date \_\_\_\_\_

Signature of Pre-Delivery Inspector \_\_\_\_\_

(Remove Dealers File Copy At Perforation)

**Intentionally Left Blank**

# DEALER DELIVERY CHECKLIST

## AFTER COMPLETION, DEALER SHOULD REMOVE AND RETAIN FOR RECORDS

This checklist that follows is an important reminder of valuable information that should be passed on to the customer at the time this **TOP DOG** is delivered.

Check off each item as you explain it to the customer.

This delivery checklist, when properly filled out and signed, assures the customer that the pre-delivery service was satisfactorily performed.

- Explain to the customer that the pre-delivery inspection was made.
- Explain to the customer all the safety precautions they must exercise when operating this unit.
- Explain recommended loads for different types of materials.
- Explain to customer that regular lubrication is required for proper operation and long life of the machine.
- Show customer the lubrication section of Owner's Manual.
- Give the customer Operator's Manual and make sure they read and understand all operating and service instructions.
- Have customer sign a completed "Warranty Registration" and mail it promptly.

Date Delivered \_\_\_\_\_

Dealer's Name \_\_\_\_\_

By \_\_\_\_\_

Signature of Original Buyer \_\_\_\_\_

Note: Warranty is not valid until warranty card is completed and returned to H&S Mfg. Co., Inc.

**Intentionally Left Blank**

## SAFETY INFORMATION



**BE  
ALERT!**

**YOUR SAFETY  
IS INVOLVED.**

THIS SYMBOL IS USED THROUGHOUT THIS BOOK WHENEVER YOUR PERSONAL SAFETY IS INVOLVED. TAKE TIME TO BE CAREFUL. REMEMBER: THE CAREFUL OPERATOR IS THE BEST OPERATOR. MOST ACCIDENTS ARE CAUSED BY HUMAN ERROR. CERTAIN PRECAUTIONS MUST BE OBSERVED TO PREVENT THE POSSIBILITY OF INJURY OR DAMAGE.

**H&S MANUFACTURING CO. INC.**

# **SAFETY INFORMATION**

Keep signs in good condition. Immediately replace any missing or damaged signs.

## **RECOGNIZE SAFETY INFORMATION**

This is the safety alert symbol. When you see this symbol on your machine or in this manual, be alert to the potential for personal injury.

Follow recommended precautions and safe operating practices.



---

## **UNDERSTAND SIGNAL WORDS**

A signal word - DANGER, WARNING, or CAUTION - is used with the safety alert symbol. DANGER identifies the most serious hazards.

Safety signs with signal word DANGER or WARNING are typically near specific hazards.

General precautions are listed on CAUTION safety signs.



**WARNING**



**CAUTION**



**CAUTION**

## **FOLLOW SAFETY INSTRUCTIONS**

Carefully read all safety messages in this manual and all safety signs on your machine. Follow all recommended precautions and safe operating procedures.

---

## SAFETY INFORMATION



# WARNING

### TO PREVENT SERIOUS INJURY OR DEATH

BEFORE YOU ATTEMPT TO OPERATE THIS EQUIPMENT, READ AND STUDY THE FOLLOWING INFORMATION. IN ADDITION, MAKE SURE THAT EVERY INDIVIDUAL WHO OPERATES OR WORKS WITH THIS EQUIPMENT, WHETHER FAMILY MEMBER OR EMPLOYEE, IS FAMILIAR WITH THESE SAFETY PRECAUTIONS. KNOW HOW TO STOP UNLOADING MECHANISM BEFORE STARTING IT.

If the machine becomes clogged, disengage truck hydraulics, stop the truck engine, remove ignition key and allow all mechanisms to stop before cleaning or working on the machine.

**DO NOT ALLOW PERSONNEL OTHER THAN QUALIFIED OPERATOR NEAR THE MACHINE.**

**DO NOT** attempt to perform maintenance or repair with truck running and hydraulics hooked to the power source.

**DO NOT** step up on machine at any time.

**DO NOT** leave truck cab when box is in operation.

**DO NOT** allow minors to operate or be near machine.

**STAY CLEAR** of rear of the **TOP DOG** at all times.

**DO NOT** clean, adjust, or lubricate the machine when any part is in operation.

**BE SURE** the machine is clear of people, tools, and any other objects before engaging hydraulics.

**NEVER** start **TOP DOG** until all guards and safety shields are secured in place.

**STAY CLEAR** of hydraulic lines, they may be under extreme pressure or heat.

**CAUTION** - Beware of low electrical wires.

Loose or floppy clothing should not be worn by the operator.

H&S Mfg. Co. always takes the operator and their safety into consideration and guards exposed moving parts for their protection. However, some areas cannot be guarded or shielded in order to assure proper operation. In addition, the Operator's Manual and decals on the machine itself warn you of further danger and should be read and observed closely.

**Study The Above Safety Rules**  
**ATTENTION - BE ALERT - YOUR SAFETY IS INVOLVED**

# CAP SCREW TORQUE VALUES

The specifications below are the torque values for fasteners as it adheres to the SAE torque value standards. All fasteners should be torqued to the proper values found in the figures below unless otherwise specified by the engineering drawing.

- Lubed torque would be any fastener that has grease, liquid Loctite, oil, etc. on the threads.
- Dry torque would be any fastener which has threads that are clean and dry and do not have any liquid Loctite or grease on them.

## Hex Head Fasteners

The figure shown below shows how to determine what SAE grade a fastener is.

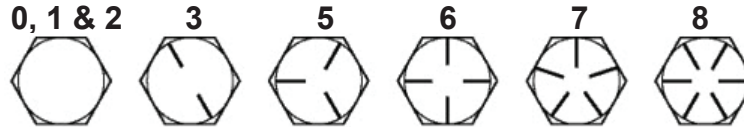

### SUGGESTED ASSEMBLY TORQUE VALUES

### WORKING TORQUE

Dia. & Thrds. per inch	SAE GR. 2-6"		SAE GR. 5		SAE GR. 8		18-8 SS	316 SS	Brass	Silicon Bronze
	Dry Ft. Lbs.	Lube Ft. Lbs.	Dry Ft. Lbs.	Lube Ft. Lbs.	Dry Ft. Lbs.	Lube Ft. Lbs.	Inch Lbs.	Inch Lbs.	Inch Lbs.	Inch Lbs.
1/4-20	5.5	4.2	8	6.3	12	9	75.2	78.8	61.5	68.6
1/4-28	6.3	4.7	10	7.2	14	10	94.0	99.0	77.0	87.0
5/16-20	11	8	17	13	24	18	132	138	107	123
5/16-28	12	9	19	14	27	20	142	147	116	131
3/8-16	20	15	30	23	45	35	236	247	192	219
3/8-24	23	17	35	25	50	35	259	271	212	240
7/16-14	32	24	50	35	70	50	376	393	317	349
7/16-20	36	27	55	40	80	60	400	418	327	371
1/2-13	50	35	75	55	110	80	517	542	422	480
1/2-20	55	40	85	65	120	90	541	565	443	502
9/16-12	70	55	110	80	150	110	682	713	558	632
9/16-18	80	60	120	90	170	130	752	787	615	697
5/8-11	100	75	150	110	210	160	1110	1160	907	1030
5/8-18	110	85	170	130	240	180	1244	1301	1016	1154
3/4-10	175	130	260	200	380	280	1530	1582	1249	1416
3/4-16	200	140	300	220	420	310	1490	1558	1220	1382
7/8-9	170	125	430	320	600	450	2328	2430	1905	2140
7/8-14	180	140	470	350	670	500	2318	2420	1895	2130
1-8	250	190	640	480	910	680	3440	3595	2815	3185
1-14	280	210	720	540	1020	760	3110	3250	2545	2885

## **SET-UP & ASSEMBLY**

**Note: Determine right and left side of the *TOP DOG* by viewing it from the rear. If instructions or parts lists call for hardened bolts, refer to Cap Screw Torque Values page to identify.**

1. Check the ***TOP DOG*** for proper assembly and adjustment.
2. Make sure that all bolts are tightened.
3. Check wheel bolts upon delivery, and periodically thereafter. Wheel bolts should be tightened to 450 ft./lbs. of torque. This torque is needed for the axle to carry its rated capacity.
3. Check the tires for proper air pressure. Refer to the manufacturer's recommended PSI rating.
4. Lubricate the ***TOP DOG*** completely. (See Lubrication Chapter in this manual).
5. Check all taillights and clearance lights that they are functioning properly.

# PREPARING FOR OPERATION

## PREPARING THE *TOP DOG*

Properly lubricate the **TOP DOG** before operating. Refer to the Lubrication Chapter of this manual for locations.

Four main apron adjustment bolts with tension springs are located on the idler shaft at the front of the box.

Check to make sure that the main apron chains are adjusted evenly before you use the **TOP DOG**. Check again after the first few loads. The main aprons should be at proper tension at all times.

Refer to the Adjustment Chapter in this manual for proper tension and adjustment.

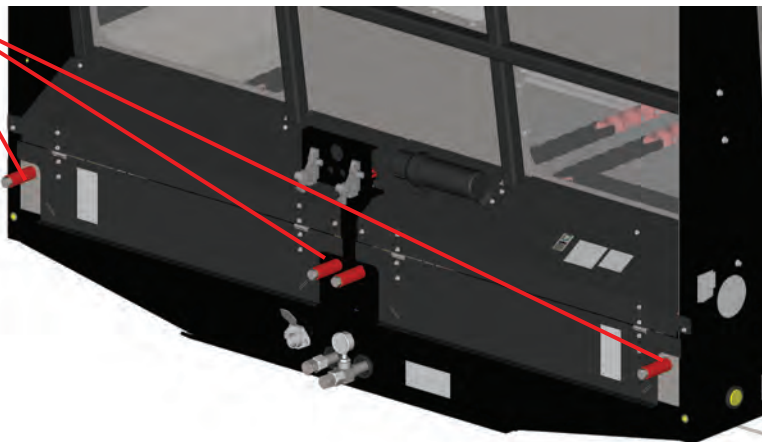

Run the unloading mechanism for several minutes. This will serve as a break-in and as a check that all parts are assembled and lubricated properly. Successful operation will be achieved by periodic adjustments and experience of the operator.

After you have run your **TOP DOG** for a few loads, check the main apron chains again for proper adjustment, as paint may initially come off the apron chains and chains may loosen.

## TRANSPORTING

When transporting on the highway or roads, regularly clean the lights and reflective tape on the sides and at the rear of the **TOP DOG**.

### ABS BRAKES

Refer to the manufacturers ABS Brake Manual for operation, adjustment, and service.



**NOTE:** Obey all state and local laws concerning the use of the **TOP DOG** on public roads.

# OPERATION

## UNLOADING

1. Park the **TOP DOG** on level ground whenever possible during unloading.
2. With the operator in the truck seat, and all others well clear of the **TOP DOG**, engage the hydraulics.
3. Engage the switch for the gate delay.
4. During unloading, move the truck forward to allow the material to fall away from the rear of box.
5. When the **TOP DOG** is empty, disengage the hydraulics.
6. Disengage the switch for the gate delay, or engage the switch for the barn doors to close them.
7. Check the rear door to make sure it is securely latched.

**NOTE:** *If the Top Dog is equipped with a reversing valve for loading bales etc., the valve handle must be positioned pulled to unload in which case it stays in the detent. If bales are being loaded into the Top Dog, the lever must be pushed and held to run the main apron chain as this is a safety to prevent damage to the Top Dog.*

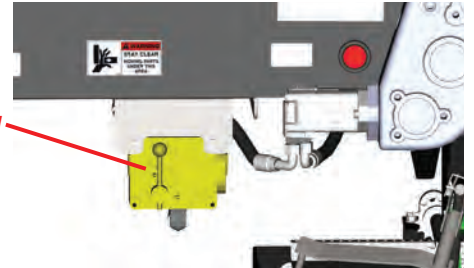

## TOP PIVOT DOOR/REAR DOOR LATCHES/GATE DELAY

Located at the bottom left, center, and right-hand side of the rear door are the door latches. The latches lock into the apron chain to hold the door closed when loading. When the hydraulics for the main apron chain are activated, the latches automatically flip to open with the movement of the apron chains. The rear door is held open by two hydraulic cylinders. This system allows for a total cleanout of the box. Upon completion of unloading & switching off the apron chain, the rear door will close.



# OPERATION

## BARN DOORS - OPTIONAL

Barn doors are optional on the *TOP DOG*. Latches for the doors are located at the bottom center of the rear doors.

These latches lock in the main apron chain of the rear drive shaft to hold doors closed when loading. When the hydraulics are activated, the main aprons turn, and the latches flip to open allowing the rear door to swing free. Upon completion of unloading, activate the switch for the rear door air cylinders to close.

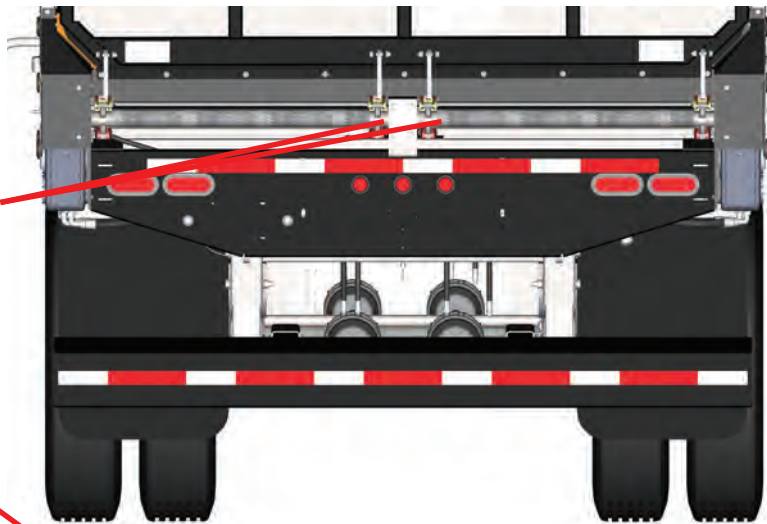

# ADJUSTMENTS

## MAIN APRON ADJUSTMENT

The four main apron adjustment bolts are spring loaded to help maintain proper tension on the apron chains.

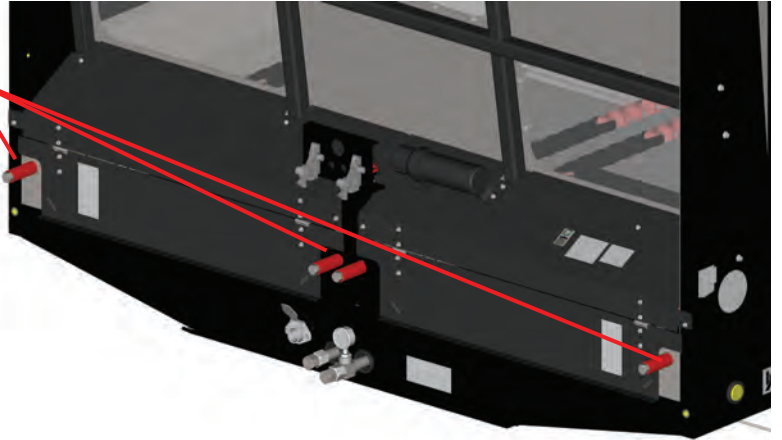

Tighten the full threaded bolts to adjust aprons. Aprons are properly adjusted when two cross slats, or about three feet of chain lift off the chain return slides from the front of the box. Maintain this when operating the box.

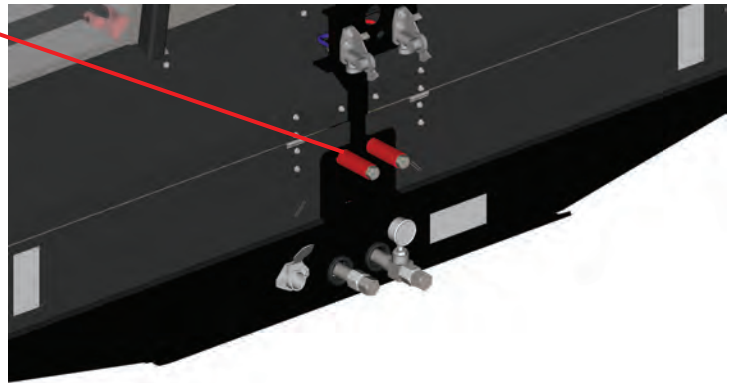

## FRONT FOLD-DOWN

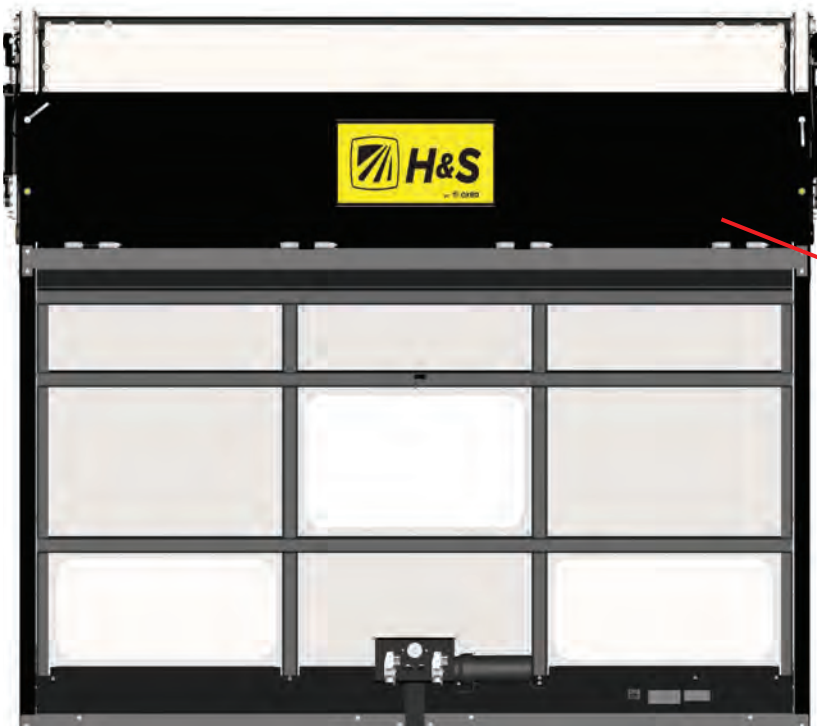

All **TOP DOG** models have the capability of unbolting and folding down the upper front panel for harvesting ahead of the forage box. An optional Electric Actuator for the fold down panel is available.

# OPTIONAL EQUIPMENT

## TIRE & WHEEL PACKAGES

There are many different tire/wheel packages available. Follow the tire manufacturer's recommended tire pressure on the tires that your **TOP DOG** is equipped with.

## ROOF HOOD

A Roof Hood is available to be installed on either side of the forage box to help minimize crop loss when blowing into it with the forage harvester.

## SCREEN FILLER KIT

A Screen Filler Kit is available for closing off the screen to minimize loss of product when hauling grain, etc.

## FLIP-DOWN FRONT ELECTRIC ACTUATOR CONTROL

The Flip-Down Front Manual Linkage System can be replaced by Electric Actuator Control for operation from the truck cab.

## TARPS

There are two tarp systems available for the **TOP DOG**. The side-to-side system will provide a nearly water-tight system ideal for grain hauling. The end-to-end arm system is ideal for forage and is a fast and easy system to use. See your dealer for these systems.



## GRAIN HOPPER

A optional rear gravity unload hopper for grains is available for the **TOP DOG**. After the hydraulics have been engaged to run the main apron chain, the operator controls the main apron speed by the variable speed control from the left rear side of the box. The flow of material can also be controlled by the gate control of the hopper.

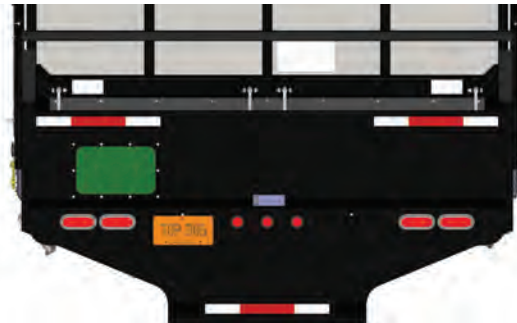

# LUBRICATION GUIDE

Become familiar with all lubrication points and establish a systematic routine to ensure complete and quick lubrication of the machine.

## GENERAL INFORMATION

**IMPORTANT:** Catch and dispose of fluid per local waste disposal regulations whenever service is performed on hydraulic components, valves, cylinders, hoses, etc.

## Grease Zerks

Grease daily during normal use and **before and after storage and after power washing.** Use a good grade of high-quality grease.

Listed are the location and quantity of zerks.

### ZERKS NOT SHOWN ON AXLES

- (4) Zerks on the Slack Adjusters
- (8) Zerks on the S-Cam Arms



Landing Gear  
2 zerks  
on the  
gearbox of  
each leg.

Top Pivot Door (4)  
1 zerk on each hinge point



Barn  
Doors  
1  
zerks  
on  
each  
hinge  
point  
of  
each  
door

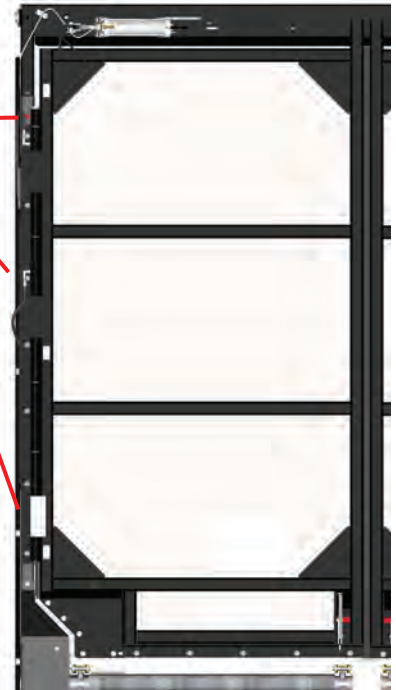

# DECAL LOCATION

Your H&S **TOP DOG** was manufactured with operator safety in mind. Located on the **TOP DOG** are various decals to aid in operation, and warn of caution areas. Pay close attention to all decals.



**DO NOT REMOVE ANY OF THESE DECALS. IF DECALS ARE LOST, DAMAGED, OR IF THE *TOP DOG* IS REPAINTED, REPLACE DECALS. REMEMBER: DECALS ARE FOR YOUR PROTECTION AND INFORMATION.**

Listed below are the decals on your **TOP DOG** Forage Box.

<u>Part #</u>	<u>Quantity</u>	<u>Description</u>
311	1	Patent Decal
1494C	8	Warning - Stay Clear Moving Parts Under This Area
1494K	2	Warning - Do Not Remove Shields
3304A	2	Warning - Stay Clear of Door Hinge Area (Barn Doors Only)
3304B	4	Danger - Stay Clear of Rear Door (Top Pivot Door Only)
8035	4	2" x 12" White DOT Strips
8039	1	Webb Wheel Torque Specs Decal
8040	1	Hutch Torque Requirement Decal
11599	3	Warning - Do not go near leaks
54034	1	Made In U.S.A.
66257	2	DOT Conspicuity Tape 2" X 25" (Grain Hopper ONLY)
84045	1	H&S Since 1967 Decal
093020	6	Grease Zerk Decal (4 w/Top Pivot Door - 8 w/Barn Doors)
93719	1	Decal is only used on boxes equipped with a reversing valve
BSSTMS20	12	DOT Conspicuity Tape 2" X 72" (Side Frame)
92294	1	DECAL, BRANDING TOP DOG
92605	1	DECAL, BRANDING 1236
92607	1	DECAL, BRANDING 1240
92597	1	DECAL, BRANDING TOP DOG
92599	1	DECAL, BRANDING 1236
92600	1	DECAL, BRANDING 1240
96929	1	DECAL, ABS
92601	1	DECAL, BRANDING TOP DOG
84044	1	DECAL, FEMA
5896A	1	DECAL, WARNING, INJURY
90626	1	DECAL, BRANDING H&S
92603	1	DECAL, BRANDING TOP DOG
77939	1	DECAL, WARNING
85912	2	DECAL, WARNING

# DECAL LOCATION

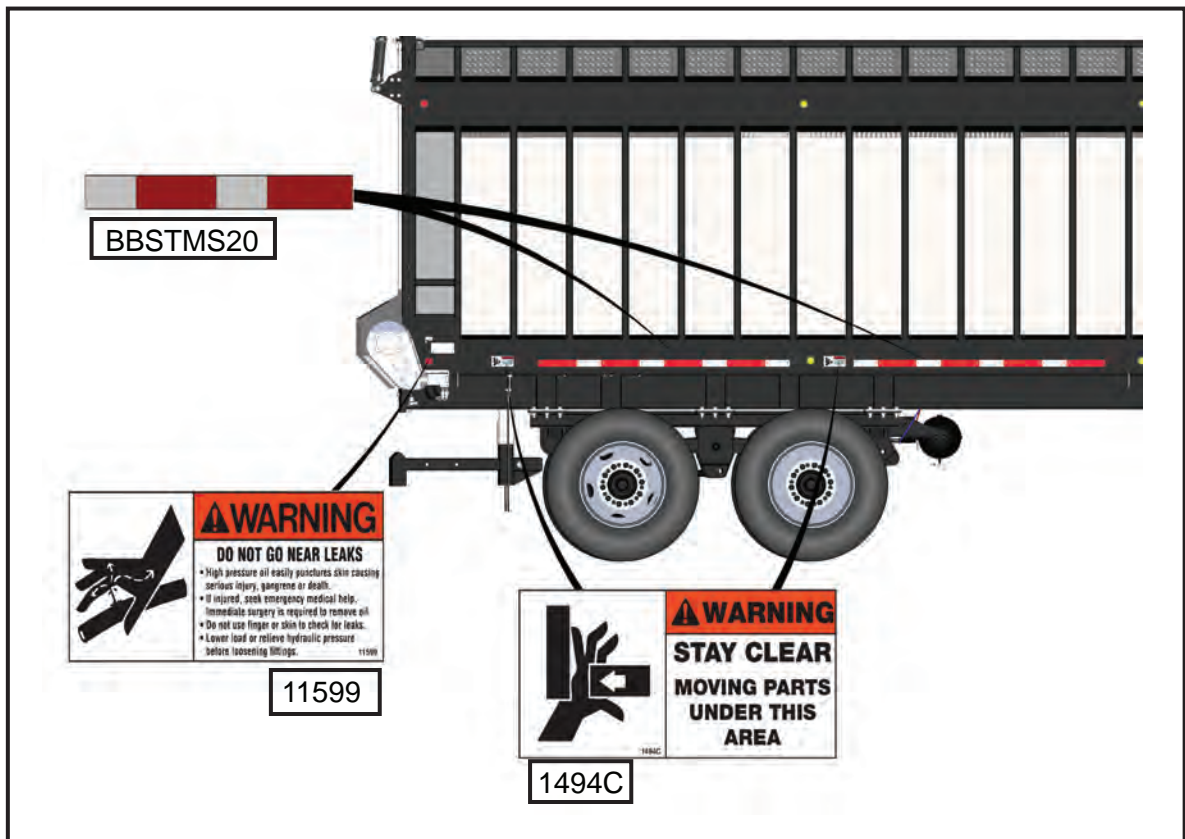
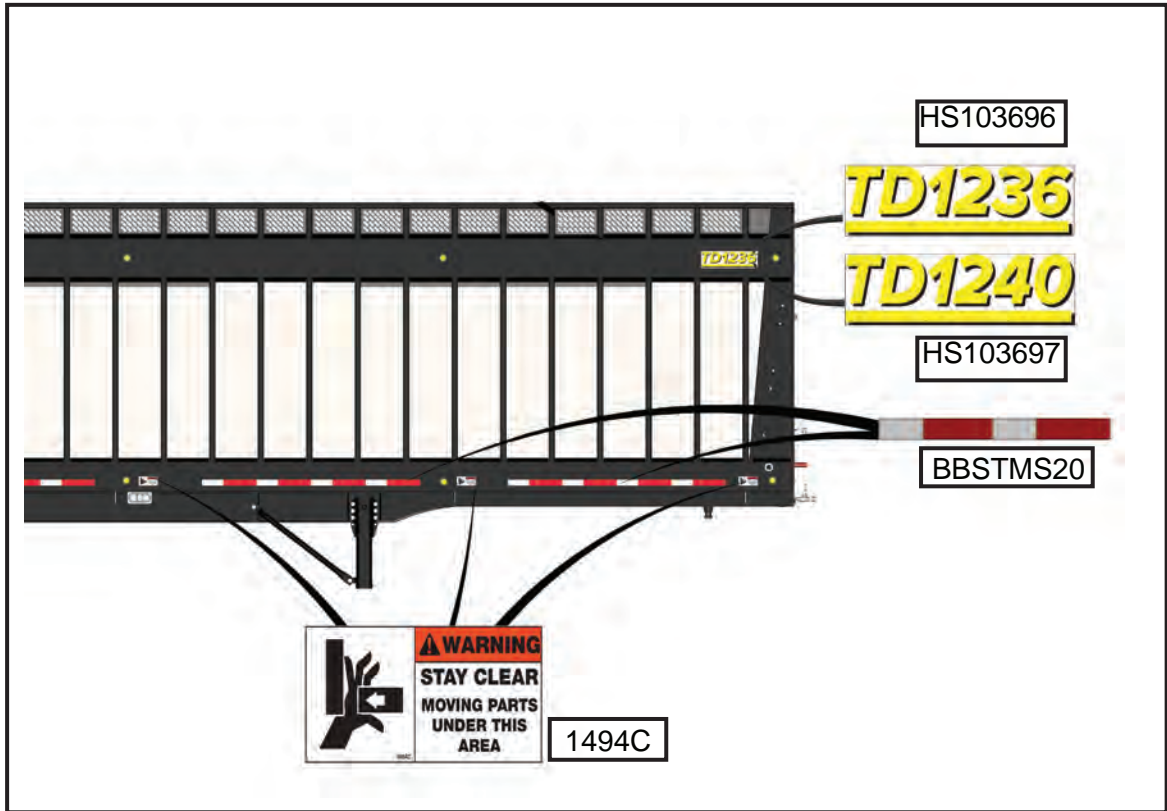

# DECAL LOCATION

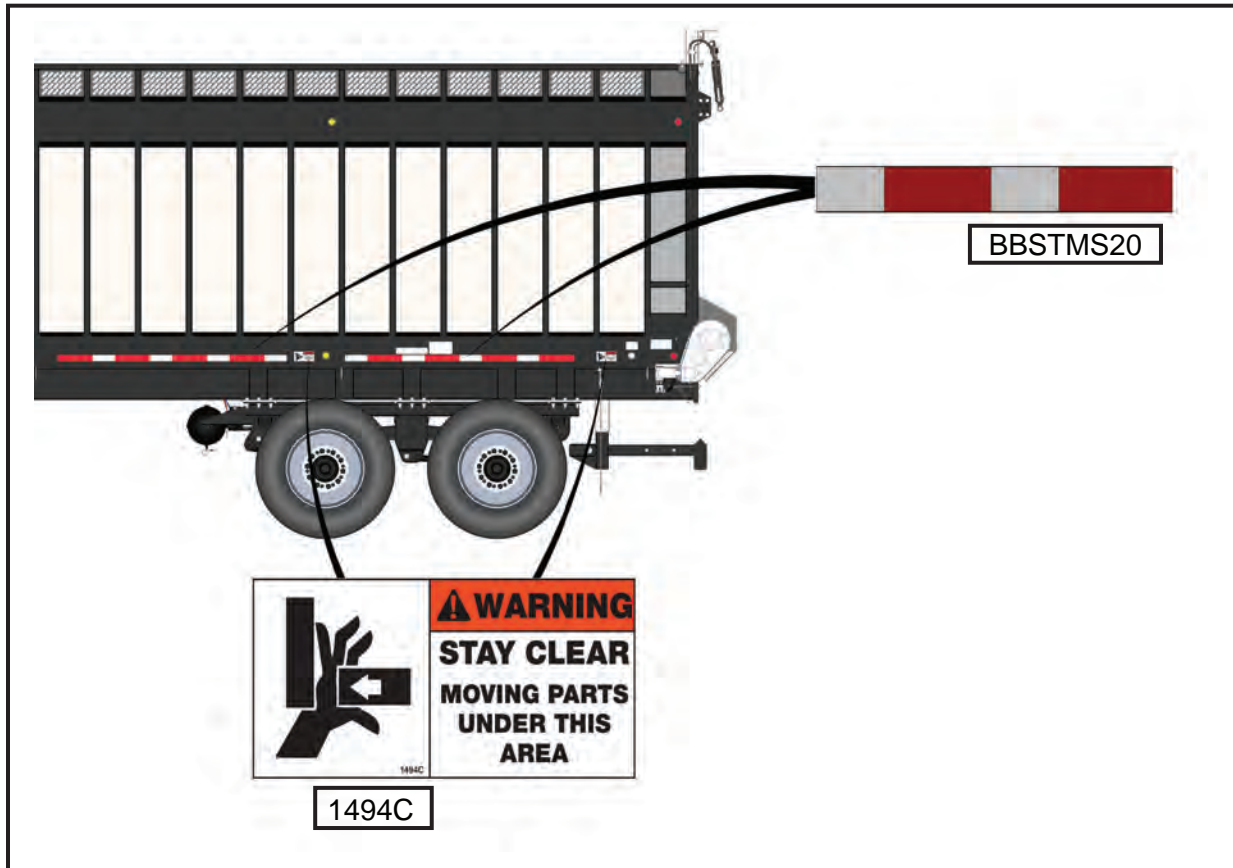
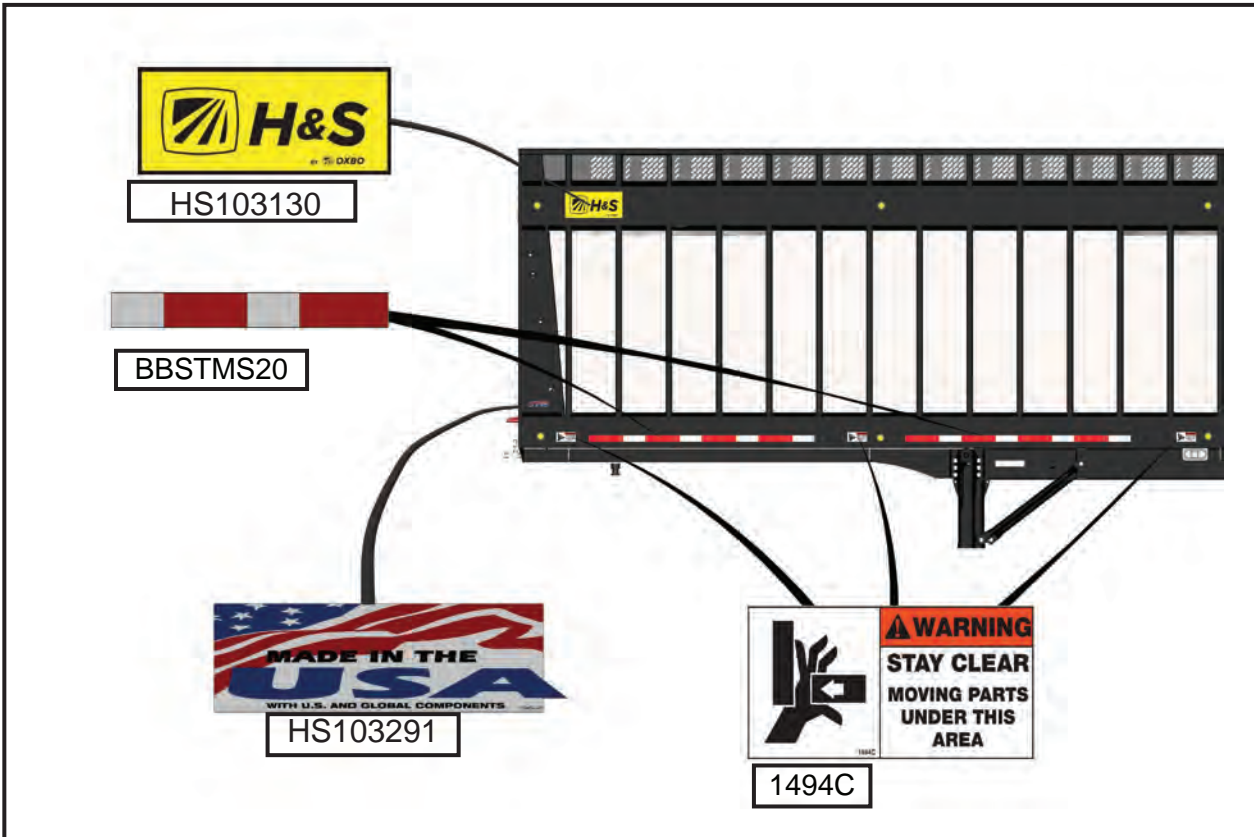



# DECAL LOCATION

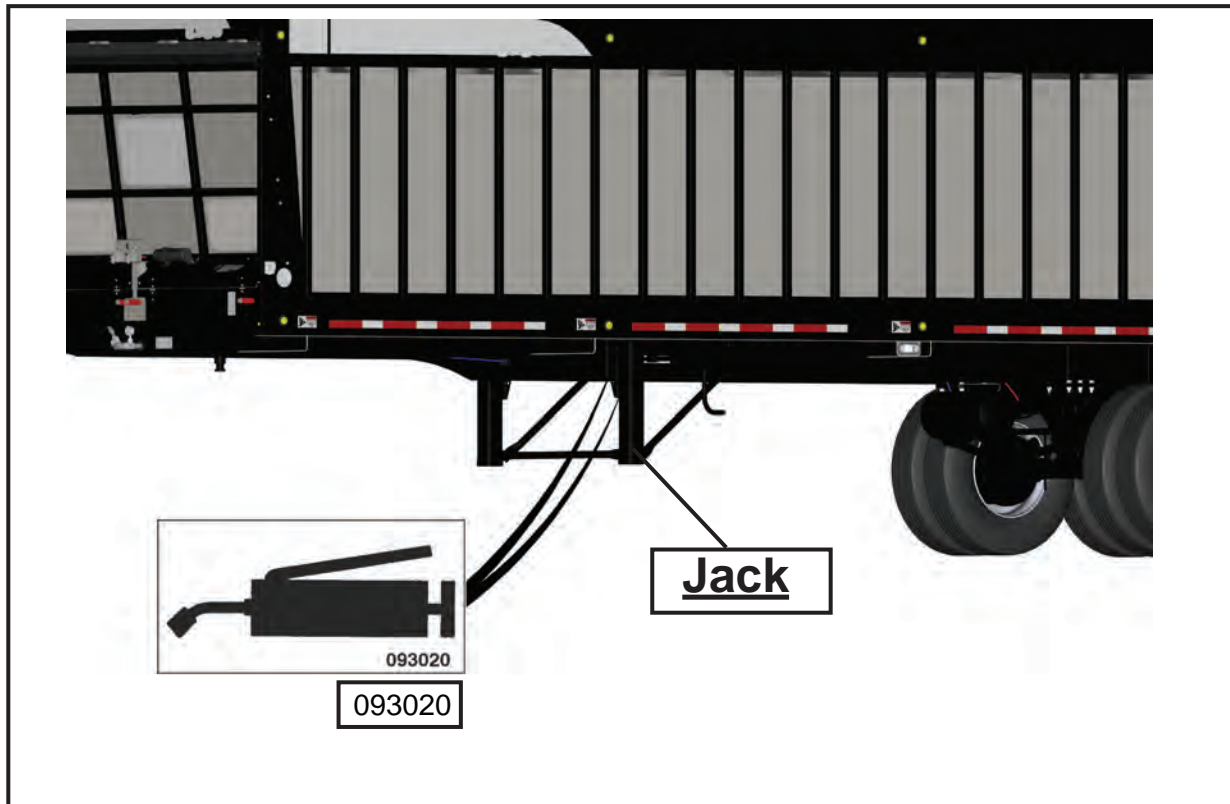
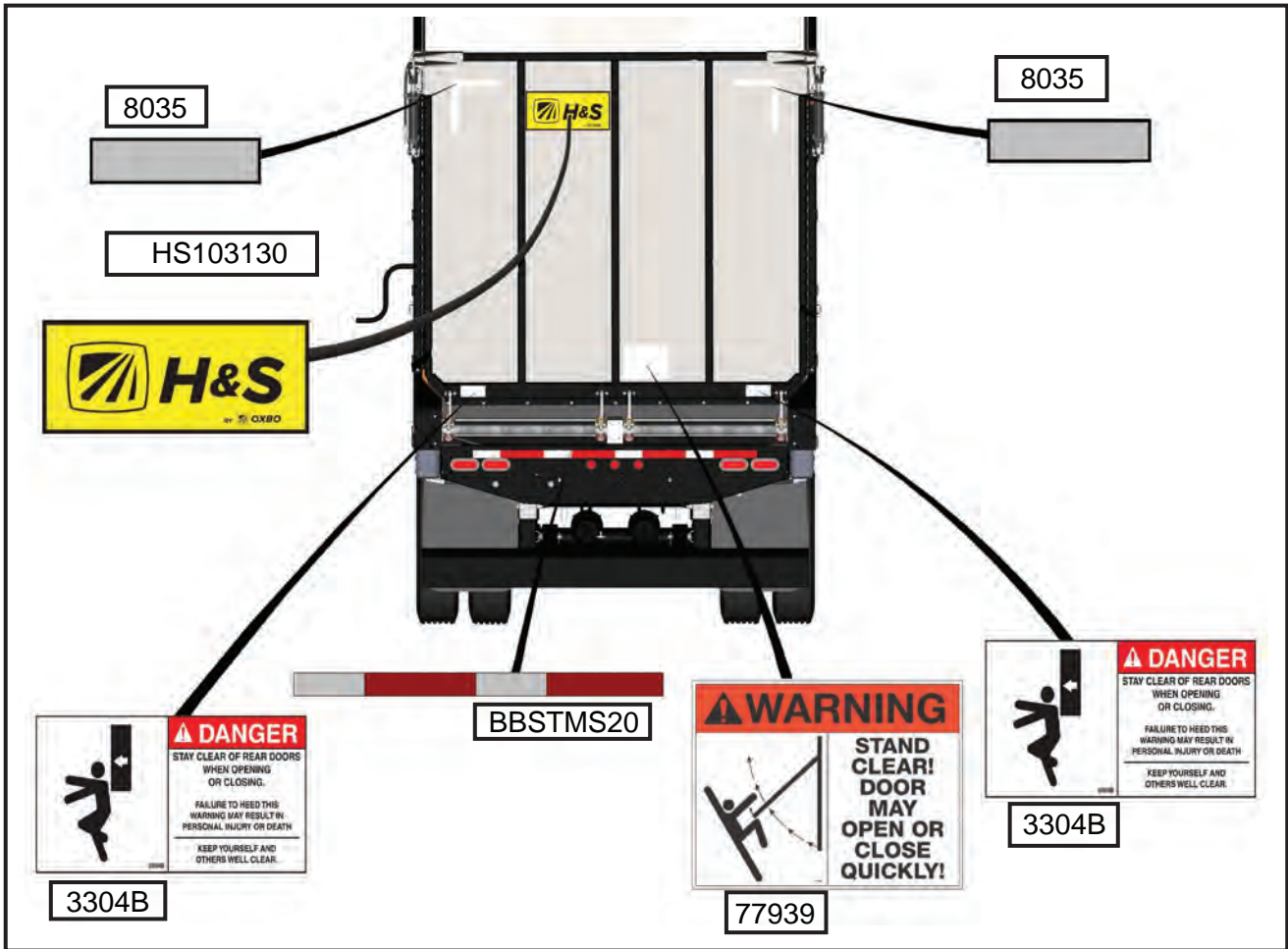

# DECAL LOCATION

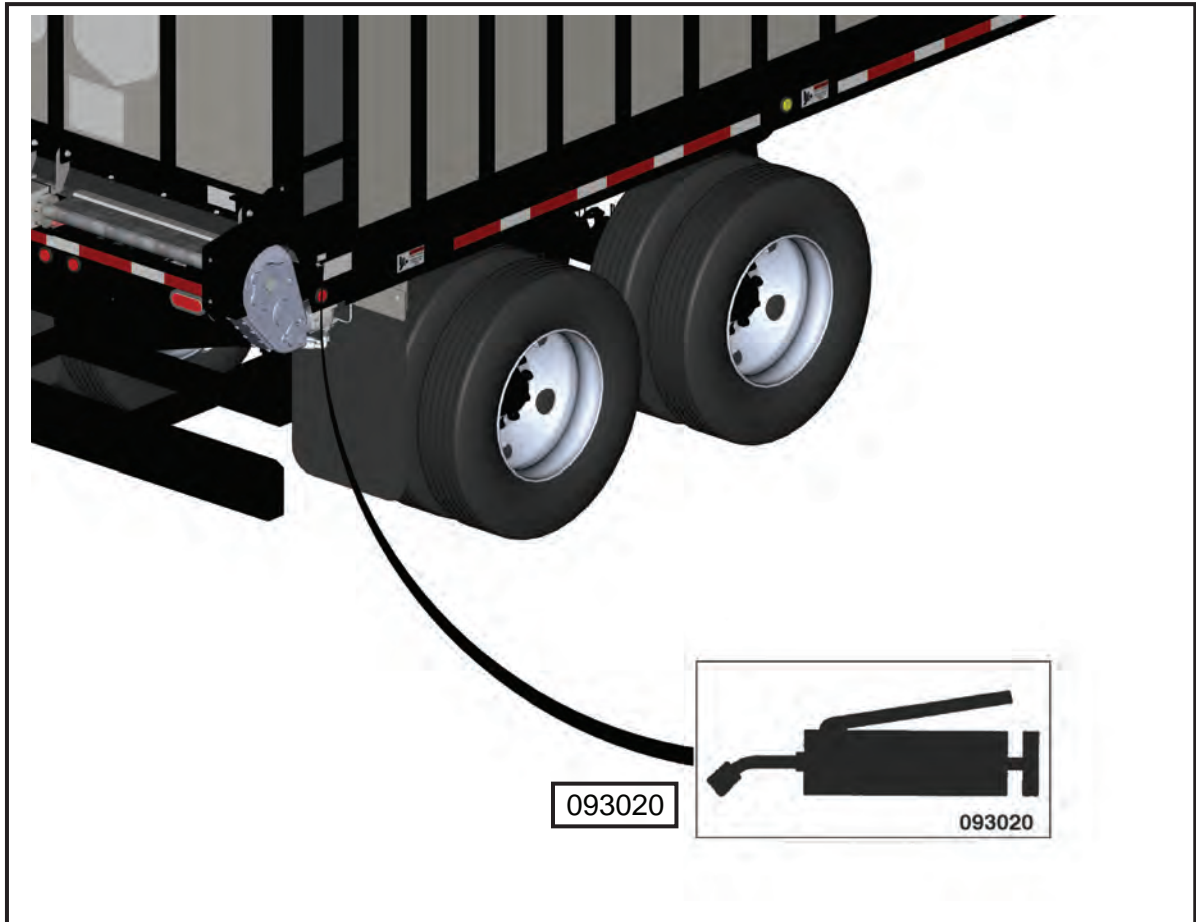
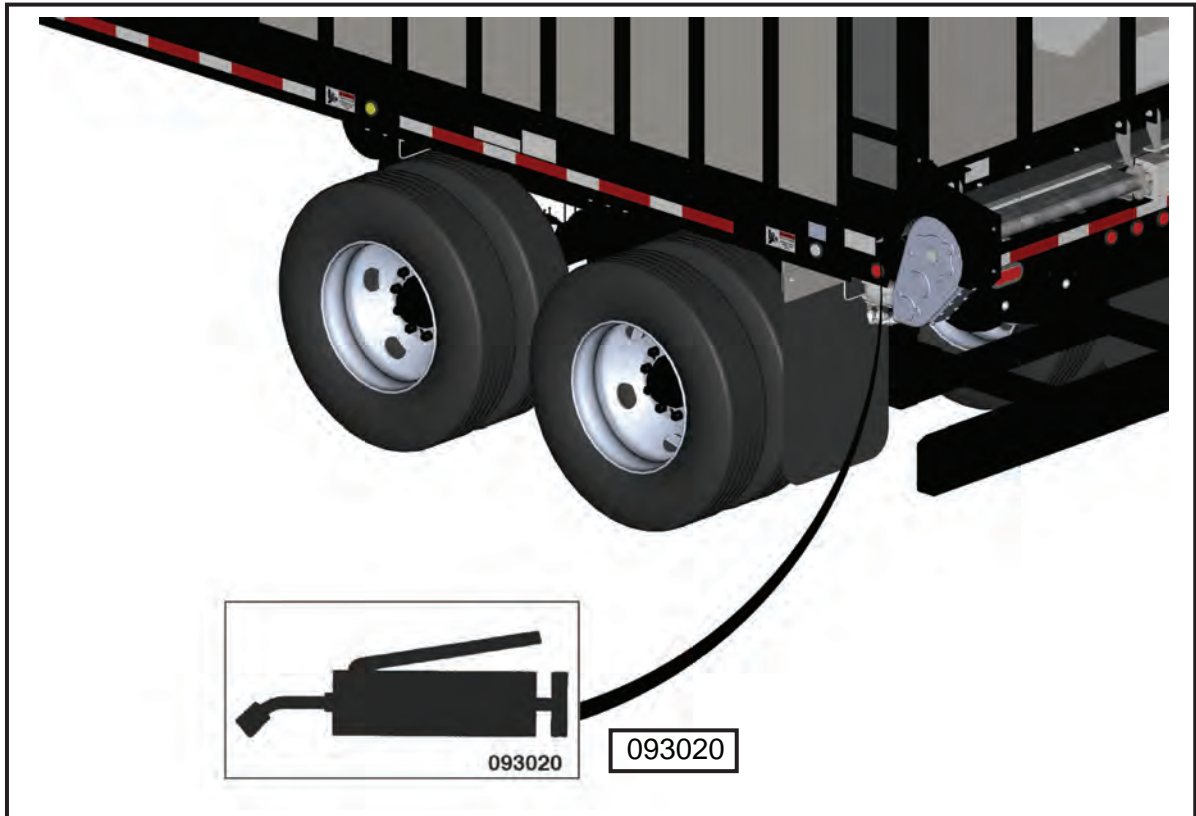

# DECAL LOCATION

## Barn Doors

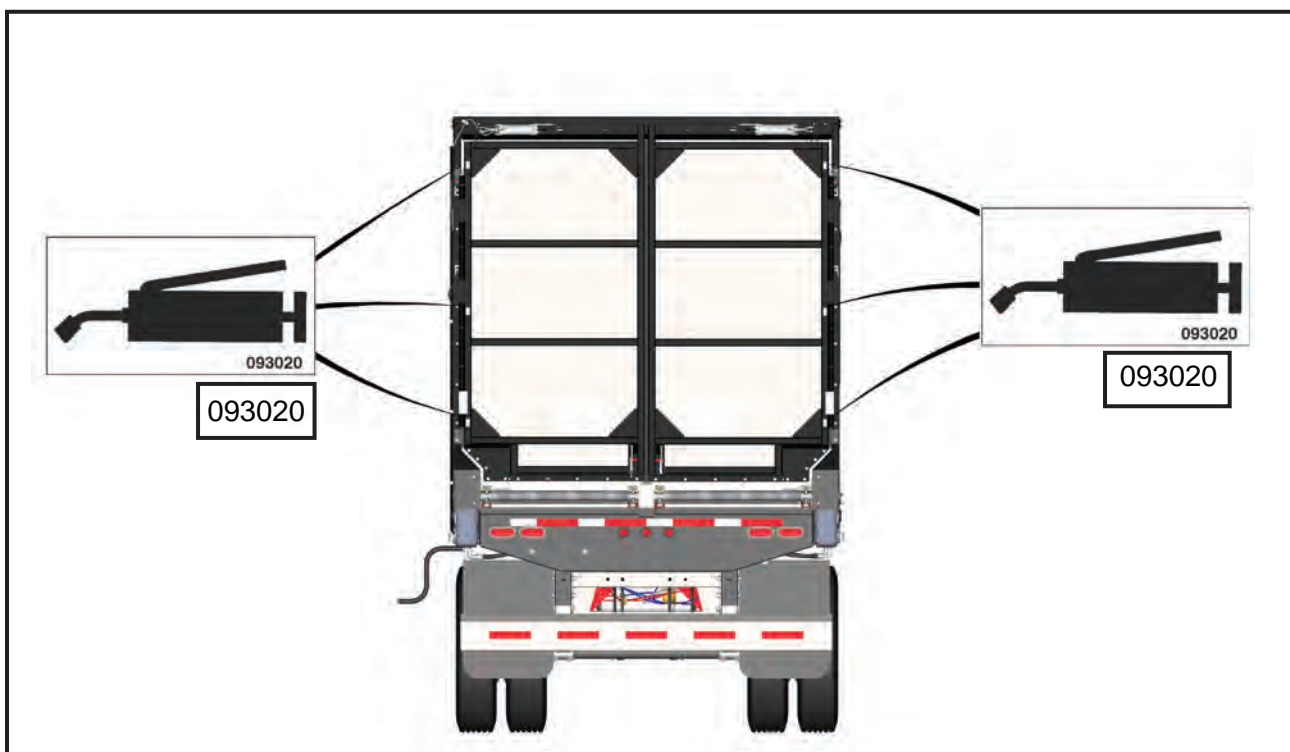
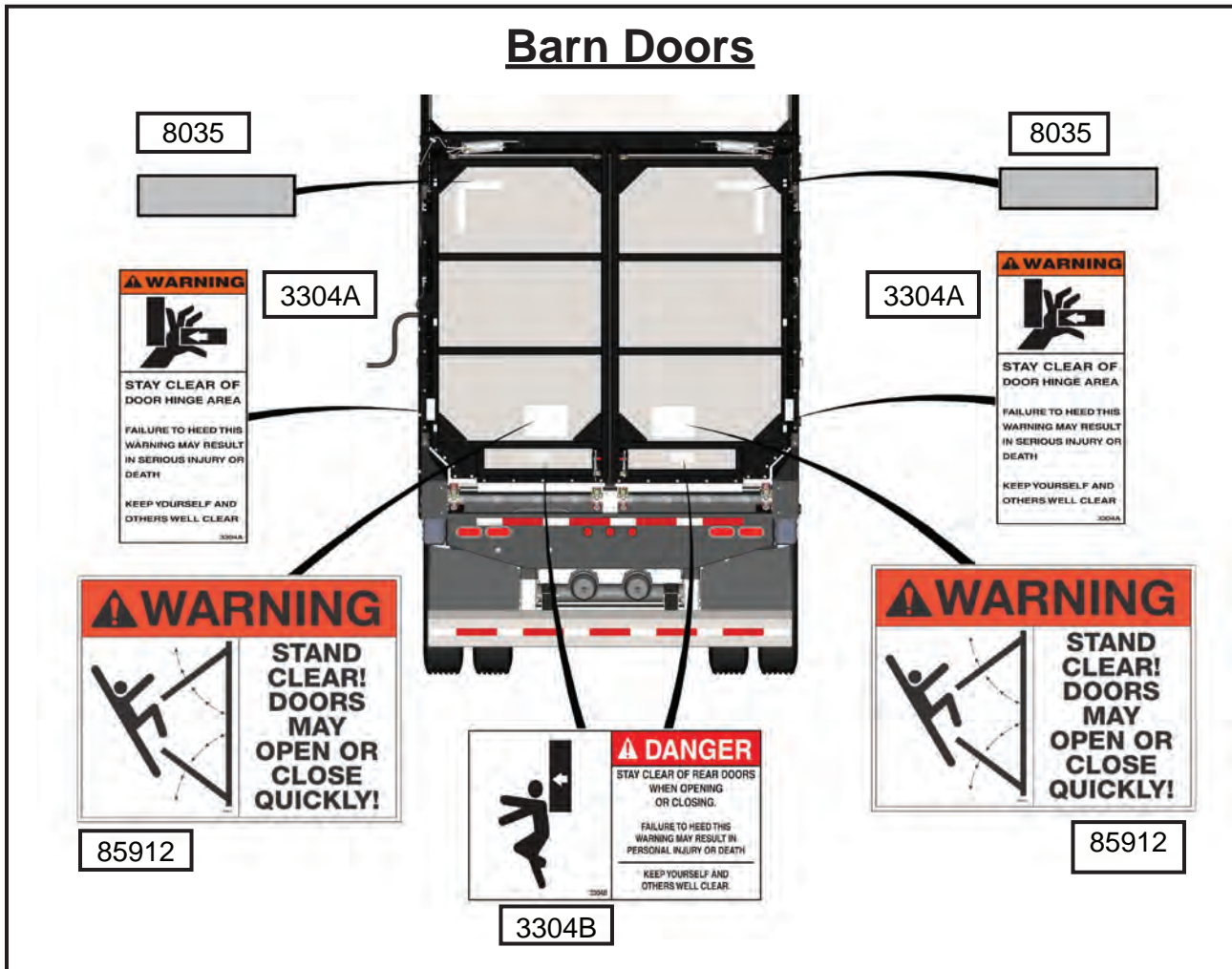

# DECAL LOCATION

## Grain Hopper



# TROUBLESHOOTING



**WARNING:**  
**MAKE SURE THE TRACTOR IS SHUT OFF AND THE TRAILER CANNOT MOVE BEFORE SERVICING THE *Top Dog*. MAINTENANCE AND REPAIR SERVICE WORK MUST BE PERFORMED BY A QUALIFIED SERVICE PERSON ONLY.**

TROUBLE	CAUSE	REMEDY
Load will not move	Truck PTO not engaged	Engage truck PTO
	Hydraulic couplers between truck and <b><i>Top Dog</i></b> are not connected or faulty	Check hydraulic couplers to make sure they are connected. Replace if faulty couplers are found
	Insufficient hydraulic flow and or pressure	Check flow and pressure in truck. Should have minimum 35 G.P.M and 2900 PSI
	Final drive chain off or broken	Replace or repair final drive chain
	Drive motor faulty or worn out	Repair or replace faulty drive motor
	Key sheared on motor drive	Replace sheared key on motor
	Final drive sprockets broken	Replace sprockets
Top hinge door will not latch	Feed left in door opening	Clean feed out of door opening
	Door bent or sprung	Straighten or replace rear door
	Top hinge pins binding	Lubricate top hinge pins
Barn doors will not close	Feed left in door opening	Clean feed out of door opening
	Door bent or sprung	Straighten or replace rear door
	Door hinge pins binding	Lubricate door hinge pins





# H&S MFG. CO.

products approved

for the

## FEMA SEAL OF QUALITY



Manufactured By:

**H&S MANUFACTURING CO., INC.**

2608 S. HUME AVE. MARSHFIELD, WI 54449

(715) 387-3414 | hsmfgco.com

