



2213 STANDARD DUTY SPREADER



WARNING

READ AND UNDERSTAND THIS MANUAL BEFORE OPERATING THIS EQUIPMENT. UNSAFE OPERATION OR MAINTENANCE OF THIS EQUIPMENT CAN RESULT IN SERIOUS INJURY OR DEATH.

Starting Serial#622PD13001

Part#92174

Rev. #01

HSMFG010725

STRONG HERITAGE - STRONG PEOPLE - STRONGER FUTURE

CONTENTS

Warranty	1
Manufacturer's Statement	2
Warranty Registration Form	3
Pre-Delivery Checklist	5
Delivery Checklist	7
Safety Information - Be Alert Symbol	9
Explanation of Safety Signs	10
Safety Decals	11-12
Safety Information - Warning - Owner Must Read and Understand	13
Cap Screw Torque Values	14
Set-Up & Assembly	15
Transporting	15
Preparing for Operation.	16
Operation	17
Adjustments	18-19
Service	20
Optional Equipment	21
Lubrication Guide	22-23
Decal Location	24-27
Troubleshooting	28
Service Notes	29-30

H&S WARRANTY

H&S Manufacturing Co., Inc. ("H&S") warrants this product to be free from defect in material and workmanship. Except as noted below, this warranty term is twelve (12) months on parts and labor, and twenty-four (24) months on parts only from the date of delivery of the product to the original purchaser by an authorized H&S dealer. Under this warranty, H&S will repair or replace, at its option, any covered part which is found to be defective in material or workmanship during the applicable warranty term. In no case will the covered repair cost of a part or parts exceed the replacement cost of that part. In no case, unless pre-authorized by H&S, will a component be replaced versus repaired unless the cost of labor and parts exceeds 75% of the cost of a new component. Warranty repairs must be performed by H&S or a dealer authorized by H&S to sell and/or service the product involved, and will use only new or remanufactured parts or components furnished by H&S. Any warranty repairs needing to be performed by a third party must be pre-authorized by H&S. Standard freight costs will be covered by H&S for any part used to make a warrantable repair, any form of express freight will not be covered unless pre-authorized by H&S. This warranty includes approved parts and labor to repair the product but does not include, and the purchaser is responsible for, any service call and/or transportation of the product to and from the dealer's place of business, for any costs related to travel, for any premium charged for overtime labor requested by the purchaser, and for any service work not directly related to any defect covered under this warranty. This warranty includes only those components of the product manufactured by H&S. Warranty for any component not manufactured by H&S including, but not limited to, engines, batteries, tires, rims, hydraulic motors, pumps, etc. are covered by the warranty, if any, provided separately by their respective manufacturers. H&S reserves the right to request the return of any failed component.

This warranty in all its parts is extended solely to the original purchaser of the product, is terminated upon any subsequent transfer or sale from or by the original purchaser, and extends no third party benefits or rights whatsoever.

The warranty term for any product used in any for hire, rental fleet or rental application, is limited to six (6) months from the date of delivery of the product to the original purchaser by an authorized H&S dealer.

This warranty does not include: (1) Any product that has been altered or modified in ways not approved by H&S; (2) Depreciation or damage caused by normal wear, use for which the product was not designed, misuse, improper or insufficient maintenance, improper operation, accident or failure to follow the product Operator's Manual recommendations and product decal recommendations; (3) Normal maintenance parts and service; (4) Repairs made with parts other than those available from H&S or performed by anyone other than H&S or a dealer authorized by H&S to sell and/or service the product involved.

To secure warranty service the purchaser must report the product defect to a dealer authorized by H&S to sell and/or service the product involved within the applicable warranty term together with evidence of the warranty start date and make the product available to that dealer within a reasonable period of time.

For these warranty terms to be in effect the selling authorized H&S dealer and/or the customer must submit the warranty registration to H&S.

THERE ARE NO WARRANTIES WHICH EXTEND BEYOND THE DESCRIPTION ON THE FACE OF THIS WARRANTY. H&S and the companies affiliated with it make no warranties, representations, or promises, express or implied, as to the performance or freedom from defect of its products other than those set forth above and NO IMPLIED WARRANTY OF MERCHANTABILITY, FITNESS OR FITNESS FOR A PARTICULAR PURPOSE IS MADE. IN NO EVENT WILL THE DEALER, H&S OR ANY COMPANY AFFILIATED WITH H&S BE LIABLE FOR INCIDENTAL OR CONSEQUENTIAL DAMAGES. The ONLY REMEDY the purchaser has in connection with the breach of performance of any warranty on H&S products are those set forth above.

The selling dealer has no authority to make any representation or promise on behalf of H&S, or to modify the terms or limitations of this warranty in any way. (12-21-22)

MANUFACTURER'S STATEMENT

Your New H&S Product has been manufactured of the finest quality materials and components. The performance you get from your machine is largely dependent upon how well you read and understand this manual and apply this knowledge. There is a right and a wrong way to do everything. Please do not assume that you know how to operate and maintain your Machine before reading this manual carefully. Keep this manual available for ready reference.

H&S reserves the right to make changes or add improvements to its products at any time without incurring any obligation to make such changes to products previously manufactured. Specifications, statements and descriptions of Products contained in this publication are subject to change without prior notification.

WARRANTY REGISTRATION

- ❖ Date of Purchase: _____
 - ❖ Purchaser Name: _____
 - ❖ Street Address: _____
 - ❖ City: _____
 - ❖ State: _____ Zip: _____
 - ❖ Phone Number: _____
 - ❖ E-mail Address: _____
 - ❖ Product: _____
 - ❖ Model Number: _____
 - ❖ Serial Number: _____
 - ❖ You have received the Operators Manual for this product. Yes _____ No _____
- Interested in receiving the H&S Newsletter? Yes _____ No _____
-

- ❖ Dealer Name: _____
- ❖ Street Address: _____
- ❖ City: _____
- ❖ State: _____ Zip: _____
- ❖ Signature: _____

❖ *All fields must be filled out to insure prompt notification of product and/or warranty updates.*

Please mail the completed WARRANTY REGISTRATION FORM to:
H&S Manufacturing Co., Inc.
2608 S. Hume Ave.
Marshfield, WI 54449

(Remove Copy At Perforation)

Intentionally Left Blank

DEALER PRE-DELIVERY CHECKLIST

AFTER COMPLETION, DEALER SHOULD REMOVE AND RETAIN FOR RECORDS

After the Manure Spreader has been completely set up, check to be certain it is in correct operating order before delivering to the customer. The following is a list of points to inspect. Check off each item as you have made the proper adjustments and found the item operating satisfactorily.

- Manure spreader was not damaged in shipment. Check for dents and loose or missing parts. Report damage immediately to H&S Manufacturing Co., Inc.
- All bolts and fasteners are tight.
- Manure spreader has been correctly assembled according to instructions in this manual.
- All grease fittings have been lubricated. Gearbox is filled to proper level.
- Guards and shields are secure.
- Wheels are properly mounted to torque specifications.
- Tires are inflated to correct pressure.
- Drive chain tension and alignment is correct.
- Decals are in place and legible.
- Main apron chains are adjusted properly.

Connect the manure spreader to a proper horsepower tractor and attach the PTO. Run the manure spreader and make sure all components operate properly.

- PTO guard turns freely.
- Main apron operates smoothly.
- Implement and all components are functioning properly.

Model Number _____ Serial # _____

Dealer's Name _____

Inspection Date _____

Signature of Pre-Delivery Inspector _____

(Remove Dealer File Copy At Perforation)

Intentionally Left Blank

DEALER DELIVERY CHECKLIST

AFTER COMPLETION, DEALER SHOULD REMOVE AND RETAIN FOR RECORDS

This checklist that follows is an important reminder of valuable information that should be passed on to the customer at the time this Manure Spreader is delivered.

Check off each item as you explain it to the customer.

This delivery checklist, when properly filled out and signed, assures the customer that the pre-delivery service was satisfactorily performed.

- Explain to the customer that the pre-delivery inspection was made.
- Explain to the customer all the safety precautions they must exercise when operating this unit.
- Explain recommended loads for different types of materials.
- Explain to customer that regular lubrication is required for proper operation and longevity of machine.
- Show customer the lubrication section of Owner's Manual.
- Give the customer Owner's Manual and make sure they read and understand all operating and service instructions.
- Have the customer sign a completed "Warranty Registration" and mail it.

Date Delivered _____

Dealer's Name _____

By _____

Signature of Original Buyer _____

Note: Warranty is not valid until warranty card is completed and returned to H&S Mfg. Co., Inc.

Intentionally Left Blank

SAFETY INFORMATION



**BE
ALERT!**

**YOUR SAFETY
IS INVOLVED.**

THIS SYMBOL IS USED THROUGHOUT THIS BOOK WHENEVER YOUR PERSONAL SAFETY IS INVOLVED. TAKE TIME TO BE CAREFUL. REMEMBER: THE CAREFUL OPERATOR IS THE BEST OPERATOR. MOST ACCIDENTS ARE CAUSED BY HUMAN ERROR. CERTAIN PRECAUTIONS MUST BE OBSERVED TO PREVENT THE POSSIBILITY OF INJURY OR DAMAGE.

H&S MANUFACTURING CO., INC.

SAFETY INFORMATION

Keep decals in good condition. Immediately replace any missing or damaged signs.

RECOGNIZE SAFETY INFORMATION

This is the safety-alert symbol. When you see this symbol on your machine or in this manual, be alert to the potential for personal injury.

Follow recommended precautions and safe operating practices.



UNDERSTAND SIGNAL WORDS

A signal word - DANGER, WARNING, or CAUTION - is used with the safety-alert symbol. DANGER identifies the most serious hazards.

Safety decals with signal word DANGER or WARNING are typically near specific hazards.

General precautions are listed on CAUTION safety decals.



WARNING



CAUTION



FOLLOW SAFETY INSTRUCTIONS

Carefully read all safety messages in this manual, and all safety decals on your machine. Follow all recommended precautions and safe operating procedures.

OBSERVE MAXIMUM TRANSPORT SPEED

The maximum transport speed for this implement is 32 km/h (20 mph).

Some tractors are capable of operating at speeds that exceed the maximum transport speed of this implement. Regardless of the maximum speed capability of the tractor being used to tow this implement, do not exceed the implement's maximum transport speed.

Exceeding the implement's maximum transport speed can result in:

- * Loss of control of the tractor/implement combination
- * Reduced or no ability to stop during braking
- * Implement tire failure
- * Damage to the implement structure or its components

Use additional caution and reduce speed when towing under adverse surface conditions, when turning, and when on inclines.

Do not attempt transport if the fully loaded implement weighs more than 1.5 times the weight of the tractor.



SAFETY INFORMATION

	<p style="text-align: center;">⚠ WARNING</p> <p style="text-align: center;">DO NOT OPERATE THIS EQUIPMENT IF THIS DECAL IS EXPOSED. REPLACE SAFETY SHIELDS.</p> <p style="text-align: right; font-size: small;">1494A</p>
---	---

	<p style="text-align: center;">⚠ WARNING</p> <p style="text-align: center;">DO NOT REMOVE SHIELDS ROTATING PARTS INSIDE</p> <p style="text-align: right; font-size: small;">12794</p>
---	---

	<p style="text-align: center;">⚠ WARNING</p> <p style="text-align: center;">DO NOT OPERATE THIS EQUIPMENT IF THIS DECAL IS EXPOSED. REPLACE SAFETY SHIELDS.</p> <p style="text-align: right; font-size: small;">71494A</p>
--	--

	<p style="text-align: center;">⚠ DANGER</p> <p style="text-align: center;">STAY CLEAR OF BEATER IF TRACTOR OR PTO IS RUNNING BEATER SHUT OFF COULD ACCIDENTALLY BE ENGAGED</p> <p style="text-align: center;">FAILURE TO HEED THIS WARNING MAY RESULT IN PERSONAL INJURY OR DEATH</p> <p style="text-align: center;">KEEP CLOTHING, YOURSELF AND OTHERS WELL CLEAR</p> <p style="text-align: right; font-size: small;">111593A</p>
---	--

	<p style="text-align: center;">⚠ WARNING</p> <p style="text-align: center;">DO NOT REMOVE SHIELDS MOVING PARTS INSIDE</p> <p style="text-align: right; font-size: small;">1494B</p>
---	---

⚠ DANGER

<p style="text-align: center;">ROTATING DRIVELINE CONTACT CAN CAUSE DEATH KEEP AWAY!</p> <p style="text-align: center;">DO NOT OPERATE WITHOUT-</p> <ul style="list-style-type: none"> • ALL DRIVELINE, TRACTOR AND EQUIPMENT SHIELDS IN PLACE. • DRIVELINES SECURELY ATTACHED AT BOTH ENDS. • DRIVELINE SHIELDS THAT TURN FREELY ON DRIVELINE. <p style="text-align: right; font-size: small;">1494L</p>

⚠ DANGER

<p style="font-size: 2em; margin: 0;">NEVER ALLOW RIDERS ON THIS MACHINE</p> <p style="text-align: right; font-size: small;">9194B</p>

SAFETY INFORMATION

⚠ WARNING



DO NOT REMOVE SHIELDS MOVING PARTS INSIDE

1494K

⚠ WARNING



DO NOT CLEAN OR WORK ON THIS MACHINE WITHOUT FIRST DISENGAGING POWER AND SHUTTING OFF TRACTOR ENGINE.

1494J

⚠ WARNING



CRUSHING HAZARD

TO PREVENT SERIOUS INJURY OR DEATH:

KEEP HANDS AND BODY OUT OF HITCH AREA WHEN ATTACHING TOWING VEHICLE.

KEEP BODY CLEAR OF CRUSH POINT BETWEEN TOWING VEHICLE AND LOAD.

KEEP FEET AND LEGS CLEAR FROM UNDER TONGUE AREA IN CASE OF POSSIBLE JACK FAILURE.

J2902

⚠ WARNING

HELP AVOID INJURY

- READ & UNDERSTAND THE OPERATORS MANUAL PROVIDED WITH THIS MACHINE. IF MISPLACED CALL H & S MANUFACTURING AT 715-387-3414 WITH MODEL AND SERIAL NUMBER.
- UNDERSTAND ALL SAFETY WARNINGS AND FUNCTION OF CONTROLS.
- KEEP SAFETY DEVICES IN PLACE AND WORKING.
- KEEP YOURSELF AND OTHERS WELL CLEAR OF MOVING PARTS.
- DISCONNECT ALL POWER BEFORE SERVICING OR CLEANING THIS MACHINE.
- DO NOT EXCEED 20 MPH

72203A

⚠ DANGER



NO STEP-STAY CLEAR

9194A

⚠ DANGER



STAY CLEAR OF END GATE ARMS

111593C

⚠ WARNING



DO NOT OPERATE THIS EQUIPMENT IF THIS DECAL IS EXPOSED. REPLACE SAFETY SHIELDS. FAILURE TO HEED MAY RESULT IN SERIOUS INJURY OR DEATH.

3894

SAFETY INFORMATION

TRACTOR:

This operator's manual uses the term "Tractor" when identifying the power or the towing source.



TO PREVENT SERIOUS INJURY OR DEATH

BEFORE YOU ATTEMPT TO OPERATE THIS EQUIPMENT, READ AND STUDY THE FOLLOWING INFORMATION. IN ADDITION, MAKE SURE THAT EVERY INDIVIDUAL WHO OPERATES OR WORKS WITH THIS EQUIPMENT, IS FAMILIAR WITH THESE SAFETY PRECAUTIONS.

KNOW HOW TO STOP UNLOADING MECHANISM BEFORE STARTING IT.

If the machine becomes clogged, disengage the PTO. Stop the tractor engine, remove ignition key, and allow all mechanisms to stop before cleaning or working on the machine.

DO NOT get off the tractor while the spreader is in operation.

DO NOT attempt to perform maintenance or repair with tractor running and PTO engaged.

DO NOT step up on machine at any time.

NEVER manually feed material into the beaters.

DO NOT allow minors to operate or be near the machine.

DO NOT ALLOW PERSONNEL OTHER THAN THE QUALIFIED OPERATOR NEAR THE MACHINE.

Before starting tractor, be sure PTO shields turn freely and PTO is securely locked to tractor.

DO NOT clean, adjust, or lubricate the machine when any part is in operation.

Keep hands, feet, and clothing away from beaters when they are revolving.

Loose or floppy clothing should not be worn by the operator. Also be sure to tie long hair back.

Be sure the machine is clear of people, tools, and other objects before engaging PTO.

DO NOT step over power take off shaft. Stay clear of PTO at all times.

NEVER start manure spreader until all guards and safety shields are secured in place.

H&S always takes the operator and their safety into consideration and guards exposed moving parts for their protection. However, some areas cannot be guarded or shielded in order to ensure proper operation. In addition, the operator's manual and decals on the machine itself warn you of further danger and should be read and observed closely.

Study The Above Safety Rules

ATTENTION - BE ALERT - YOUR SAFETY IS INVOLVED

CAP SCREW TORQUE VALUES

The specifications below are the torque values for fasteners as it adheres to the SAE torque value standards. All fasteners should be torqued to the proper values found in the figures below unless otherwise specified by the engineering drawing.

Lubed torque would be any fastener that has grease, liquid Loctite, oil, etc. on the threads.

Dry torque would be any fastener which has threads that are clean and dry and do not have any liquid Loctite or grease on them.

Hex Head Fasteners

The figure shown below shows how to determine what grade a fastener is.

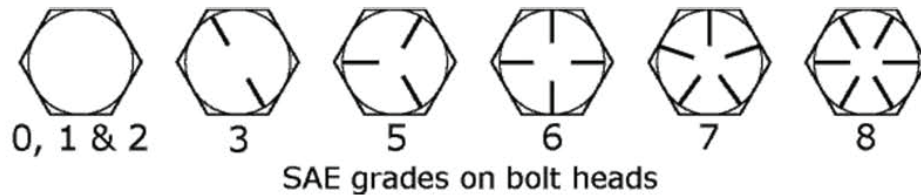

Diam & Thrds Per Inch	SUGGESTED ASSEMBLY TORQUE VALUES						WORKING TORQUE			
	SAE GRADE 2 -6"		SAE GRADE 5		SAE GRADE 8		18-8 SS	316 SS	BRASS	SILICON BRONZE
	Dry FT. LB.	LUB FT. LB.	Dry FT. LB.	LUB FT. LB.	Dry FT.LB.	LUB FT. LB.	IN LBS	IN LBS	IN LBS	IN LBS
1/4-20	5.5	4.2	8	6.3	12	9	75.2	78.8	61.5	68.6
1/4-28	6.3	4.7	10	7.2	14	10	94.0	99.0	77.0	87.0
5/16-18	11	8	17	13	24	18	132	138	107	123
5/16-24	12	9	19	14	27	20	142	147	116	131
3/8-16	20	15	30	23	45	35	236	247	192	219
3/8-24	23	17	35	25	50	35	259	271	212	240
7/16-14	32	24	50	35	70	50	376	393	317	349
7/16-20	36	27	55	40	80	60	400	418	327	371
1/2-13	50	35	75	55	110	80	517	542	422	480
1/2-20	55	40	85	65	120	90	541	565	443	502
9/16-12	70	55	110	80	150	110	682	713	558	632
9/16-18	80	60	120	90	170	130	752	787	615	697
5/8-11	100	75	150	110	210	160	1110	1160	907	1030
5/8-18	110	85	170	130	240	180	1244	1301	1016	1154
3/4-10	175	130	260	200	380	280	1530	1582	1249	1416
3/4-16	200	140	300	220	420	310	1490	1558	1220	1382
7/8-9	170	125	430	320	600	450	2328	2430	1905	2140
7/8-14	180	140	470	350	670	500	2318	2420	1895	2130
1-8	250	190	640	480	910	680	3440	3595	2815	3185
1-14	280	210	720	540	1020	760	3110	3250	2545	2885

SET-UP & ASSEMBLY

NOTE: Determine right or left side of the Manure Spreader by viewing it from the rear. If instructions or parts lists call for hardened bolts, refer to the Cap Screw Torque Values Chart.

PREPARING MANURE SPREADER

The Manure Spreader may be shipped without the wheels/tires installed.

1. Attach the wheels with tires using the lug nuts furnished and torque the mounting hardware to the appropriate torque. Wheel bolts should be tightened at 60-65 ft./lbs. of torque.
2. Check the tires and inflate to the recommended pressure (IF240/80R15 tires @ 46 psi).
3. Check for proper assembly and adjustment and make sure that all bolts are tightened.
4. Securely retighten after a few hours of operation as bolts can loosen up on new machinery.
5. Lubricate the machine completely, check the oil level of the gearbox, and fill if necessary.

TRANSPORTING

SAFETY CHAIN (Optional)

Follow state and local regulations regarding use of a safety chain and transport lighting when towing farm equipment on public highways. A proper safety chain should be used to retain the safety connection between the towing and towed machines, in the event of separation of the primary attaching system. Check with local law enforcement agencies for your own particular regulations. Never tow the manure spreader on a public highway at a speed greater than 20 mph (32 kph).

1. Chain is sufficiently slack to allow turns and movements of either the tractor or the manure spreader, without placing tension on the chain.
2. Chain is of sufficient strength to hold the decoupled implement (and its load) and tow it to the shoulder.

REFLECTORS

Regularly clean the reflective tape at the rear of the spreader. There is a holder provided for your SMV sign. Unless otherwise prohibited, use a slow-moving vehicle emblem.

PREPARING FOR OPERATION

TRACTOR CONNECTIONS

Tractor Hitch

Fasten the spreader hitch to the tractor drawbar with a **hitch pin with a safety locking device**. Remove the weight from the jack (jack is not to be used when spreader is loaded). Remove jack from pipe mount and place on storage mount located on the left front of spreader. This allows protection of jack from tractor tires during turns. The hitch of the spreader is designed for a standardized tractor hitch. Adjust the drawbar so that it is 13 to 17 inches above the ground. Extend or shorten it so that the horizontal distance from the end of the tractor power takeoff shaft to the center of the hitch pin hole is 14 inches for 540 PTO as shown in drawing. An improperly located hitch point may cause damage to the universal joints of the power takeoff. Secure the drawbar so that the hitch pin hole is directly below the power drive line.

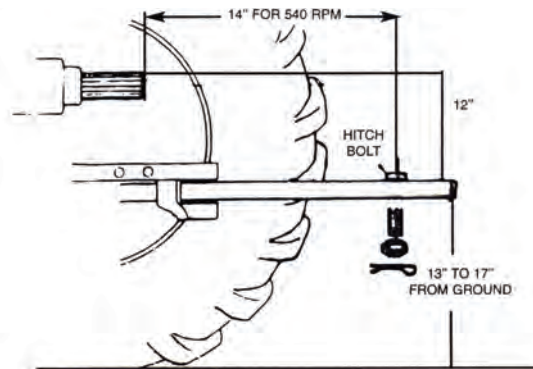

PTO

Attach the PTO of the spreader to the tractor by sliding the spring loaded locking collar on PTO yoke rearward, then sliding it onto the tractor PTO shaft. Release spring-loaded collar. Be sure the pins fall into the groove of the tractor PTO shaft and collar snaps forward into locking position. Attach the chain for the back half of the PTO to the manure spreader frame as shown in the picture to secure the PTO shield. Attach the chain for the front half of the PTO to the tractor drawbar to secure the PTO shield.



CAUTION: Do not use a steel hammer to aid in joining PTO parts.

If this implement is attached to a tractor with a clevis hitch (hammer-strap) style drawbar, the hammer-strap must be removed to prevent damage to the IID guarding and the IID telescoping members. [See Figure 1]

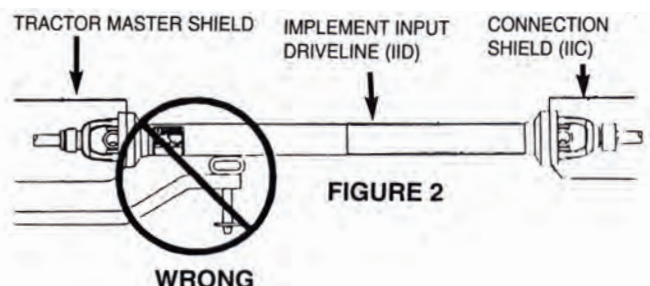
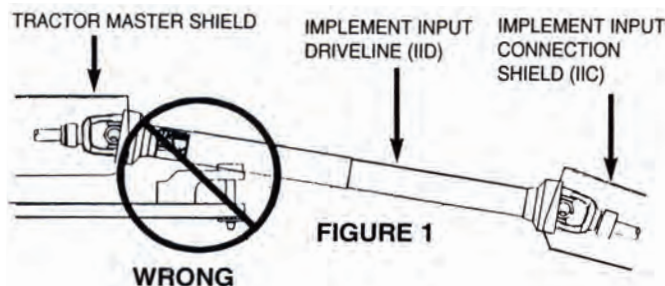

If this implement is attached to a tractor with an offset in the drawbar, be certain it is in the down position to prevent damage to the IID guarding and the IID telescoping members. [See Figure 2]

OPERATION

LOADING

In freezing weather, make certain that the apron chain is not frozen to the spreader floor or any lumps of manure are frozen to the floor. Begin loading the spreader at the front end and work toward the rear until loading is completed. Loading this way permits the material to be spread uniformly. Loading front to rear is particularly important when the spreader is loaded by a mechanical loader because this type of load requires more power to spread than others loads. When hauling extremely heavy materials with a large portion of dirt, it may be necessary to reduce the load size to prevent excessive shear bolt breakage. Never dump material onto the beater. Do not use extra sideboards. Do not overload the manure spreader. Overloading decreases spreading effectiveness. Do not load more than 15 inches above the beater.

SPREADING

NOTE: Two speed apron drive and beater engage/disengage mechanisms are contained in a single gearbox at the rear of spreader. This gearbox is controlled by one rope leading to the tractor.

1. Make sure that the gear box is in the “low” position. with the shifter dog all the way to the “low” side of the indicator slot.
2. Raise the hydraulic endgate (if so equipped).
3. Throttle tractor down, engage PTO, then increase the throttle to 540 RPM and begin driving forward. NEVER operate the spreader with a PTO speed greater than 540 RPM.
4. The apron speed may be increased from 4-1/2 fpm to 8-1/2 fpm (at 540 RPM) by pulling once on the control rope until the shifter stops and locks into the “high speed” position. The beater will continue to operate in this position.
5. When the spreader is almost empty, the bed can be cleaned out by again, pulling once on the control rope until the shifter dog locks into the “clean-out/beater disengaged” position. The beater will stop and the apron will continue to run in the “high” speed position, thus saving unloading time.
6. When spreader is empty, SHUT OFF PTO. With the PTO off, pull the control rope once again and release it. The shifter will return to the “low” position, ready to begin unloading the next load.

DO NOT SHIFT FROM CLEAN OUT TO LOW POSITION WITH THE PTO RUNNING.

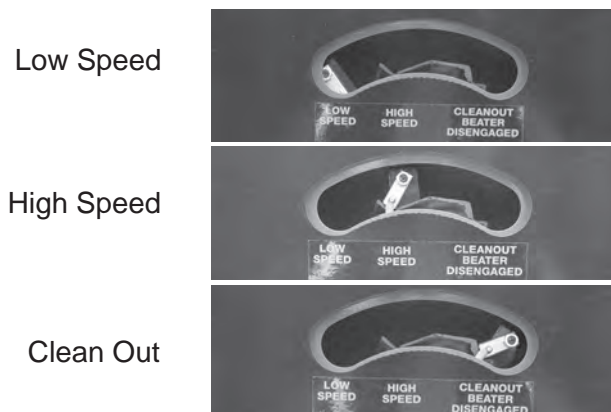

FAILURE TO FOLLOW THE RECOMMENDED ADJUSTMENTS WILL VOID WARRANTY

ADJUSTMENTS

DRIVE CHAIN

To adjust front drive chain, slightly loosen 2 bolts holding pillow block bearing at rear of front jack shaft. Loosen jam nut on tightener rod. Turn adjusting nut (located at the right hand front side of spreader) clockwise. There should be 1/2" deflection at the center of the drive chain. Overtightening or too loose of a chain will result in excessive wear on the bearing, chain and sprockets. Retighten bolts holding bearing. Recheck chain tension. Retighten jam nut.

Shields Removed For Clarity

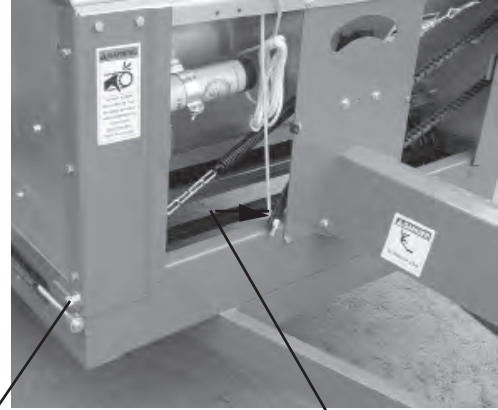

TIGHTENER BOLT

BEARING

APRON SPEED AND BEATER CONTROL

One cable controls the beater and apron drive two speed gearbox. To compensate for wear or stretching of this cable, adjust the turnbuckle behind shield at left hand front of spreader.

Shields
Removed
for
Clarity



ATTACHING CHAIN

TURNBUCKLE

Refer to drawing at right to properly adjust manure spreader. Position speed control in HI Speed.

Measurement (A) is 2-1/2 inches.

This is factory set and should not be changed. Do not move bracket or collar on control rod. The distance between collar and face of gearbox should be as follows for the different speeds: (distance B)

LO Speed: 0" (tight against gearbox)

HI Speed: 7/16 - 1/2"

CLEAN OUT: 3/4 - 1 1/16"

If collar on control rod does not pull tight to gearbox in LO Speed, after HI Speed has been properly adjusted, apply more tension to the return spring located at the front of the spreader behind the right shield. To adjust spring, hook end of spring one chain link shorter on spring attaching chain.

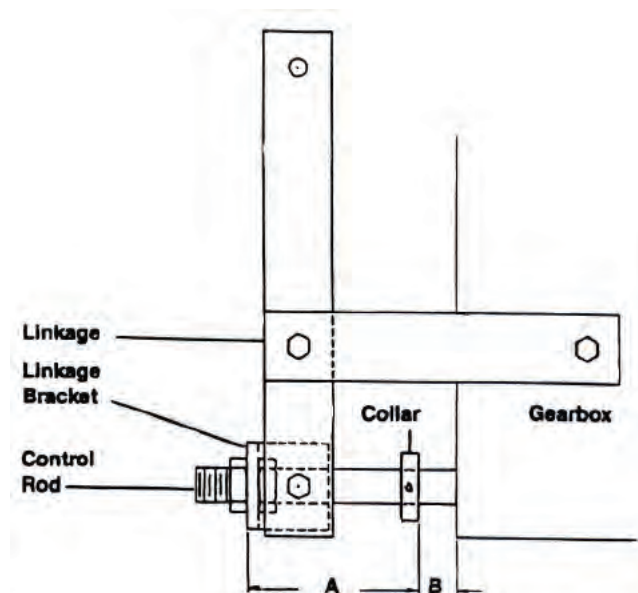

ADJUSTMENTS

APRON

1. Adjust the apron by loosening the mounting bolts on the chain slides on the outside of the frame. Mounting bolts shown in the drawing.
2. Tighten the adjusting bolts until the apron has no sag between the rear drive sprockets and chain slides under spreader.

NOTE: Tighten the adjusting bolts (on each front corner) equally on each side so that the apron slats run parallel with the ends of the bed. The apron will be damaged if the machine is operated with one end of the apron slats running ahead of the opposite end. Do not tighten the apron chains excessively.



ADJUSTING
BOLT

MOUNTING BOLTS

APRON WORM DRIVE CHAIN

The main apron drive chain is kept tight with a roller type adjustable tightener. Periodically check tension on chain. Chain is properly adjusted when there is 1/8" deflection in center of chain. Also check tightener for wear and replace when necessary. Failure to maintain proper tension will result in excessive wear to the chain and sprocket.

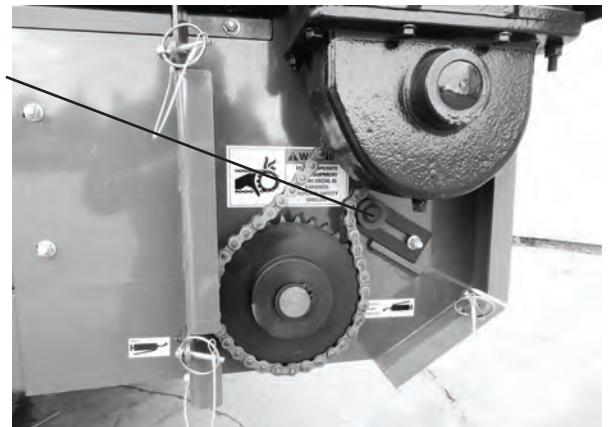

SERVICE

SHEAR BOLT

The beater and apron drive are protected by one shear bolt. Two extra shear bolts are provided. Shearing of the bolt is normally due to foreign objects in the manure or starting the spreader PTO too quickly with high tractor RPMs. Always use H&S shear bolts.

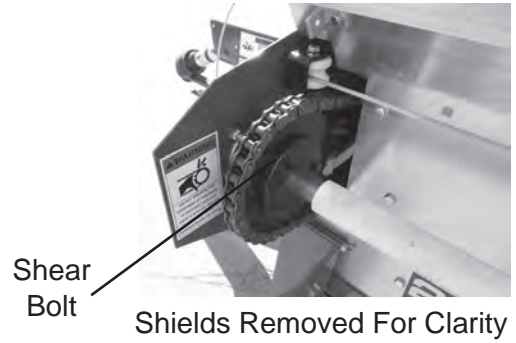

WHEEL HUBS

To service or adjust the wheel hubs, tighten the castellated nut on the spindle to the point where there is no end-play and a slight drag on the bearings. Replace the cotter key with a new one of the correct size.

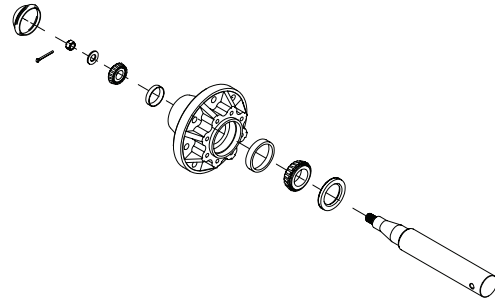

TIRES & WHEELS

Check the tire pressure after every 50 hours of operation. Tires should be inflated to the appropriate pressure listed in the table.

<u>Tire</u>	<u>Pressure</u>
10.00x15	40 PSI
IF240/80R15	46 PSI



Wheel lug torque should be checked after every 50 hours of operation and tightened to the appropriate torque.

Wheel bolts must be tightened between 60-65 ft./lbs. of torque.

OPTIONAL EQUIPMENT

REAR PAN

The rear pan shown is optional equipment.

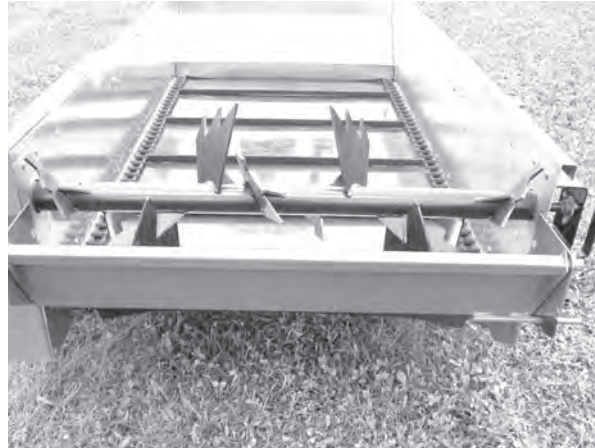

SEMI-LIQUID HYDRAULIC ENDGATE

The semi-liquid hydraulic endgate is also optional. The rear pan and hydraulic endgate may be used together on this model.

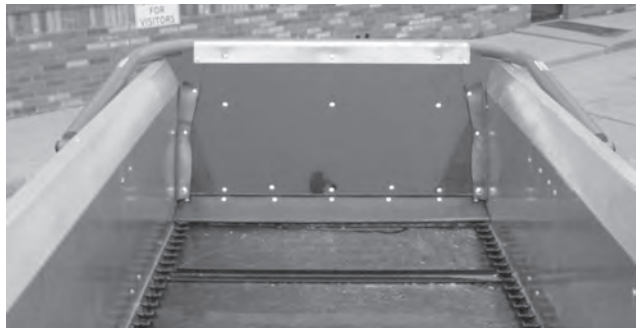

HYDRAULIC ENDGATE

TOP BEATER

The top beater shown below is optional equipment.



TOP BEATER

LUBRICATION

The operator should become familiar with all lubrication points and establish a systematic routine to ensure complete and quick lubrication of the machine.

GENERAL INFORMATION

IMPORTANT: *Catch and dispose of fluid per local waste disposal regulations whenever service is performed on hydraulic components, valves, cylinders, hoses, etc.*

GREASE FITTINGS

There are numerous grease fittings on the spreader, If these are lubricated properly and often enough, it will prolong the life of the spreader. (Grease every 20 hours, every 100 loads or semi annually and also **before storage and after power washing.**) Make certain that the grease fittings are free of paint and dirt. Force a high-quality grease into them until the grease comes out around the shaft on the sleeve-type bearings. On the sealed ball bearings, grease should be added slowly until a slight bead forms at the seals indicating the correct amount of lubricant. Wipe off excess grease to prevent the accumulation of chaff and grit around the bearings.

GEARBOX

Before using your new machine, check the oil level in the gearbox located at the left rear of the spreader. Keep the gearbox filled to the center of the top shaft of the gearbox with 75W90 gear lube. Be sure to change the oil annually.

DRIVE CHAINS

Lubricate the drive chains with a light machine oil. Keep chains aligned with sprockets, this will lengthen the life of the sprockets and chain. Lubricate chains often.

PTO ASSEMBLY

Care must be taken to keep the male and female driving elements well-lubricated and free sliding. Failure to observe this precaution will result in excessive pressure being required to collapse or extend the assembly while subject to operating torque. This excessive force may damage or displace the jackshaft bearings. DO NOT lubricate the shield surfaces. The shield surfaces must be kept dry, as dirt accumulation on them will quickly cause these units to bind and not rotate. Care should also be taken to be certain that the rotating integral shields are not dented or damaged, as this also will result in excessive force being applied against the jackshaft. Damaged shields also cause obvious difficulties when installing the assembly. If at any time the shields do not turn freely, they should be checked to determine the cause and repaired or cleaned. To avoid damage to the main drive bearings, avoid turning sharp corners while PTO is running.

Start and Stop the PTO slowly to avoid damage to the drive line.

LUBRICATION

GREASE ZERK LOCATIONS

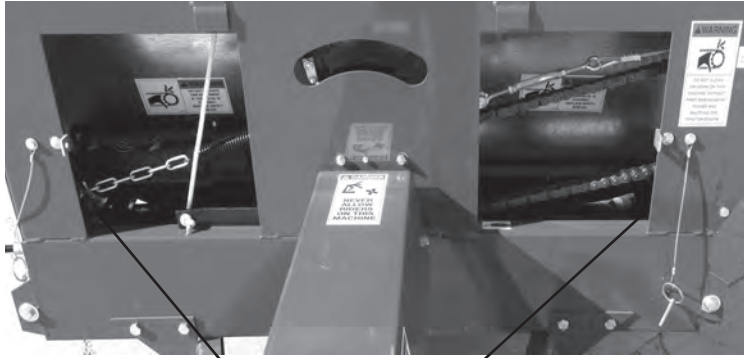

(1) on each front idler sprocket behind the shields

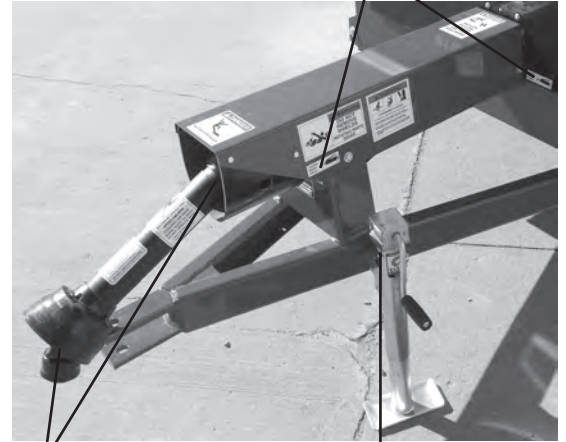

(1) at each end of the input shaft

(1) at each end of the PTO shaft

(1) on jack



(1) on the side shaft

(1) on each hydraulic endgate arm pivot if applicable

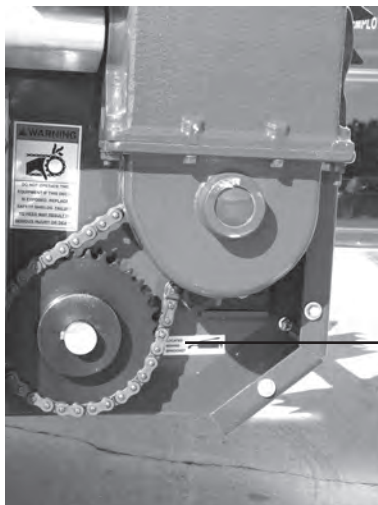

(1) on the beater shaft

(1) on each end of the drive shaft



DECAL LOCATION

Your Manure Spreader was manufactured with operator safety in mind. Located on the Manure Spreader are various decals to aid in operation, and warn of danger or caution areas. Pay close attention to all decals on your Manure Spreader.



DO NOT REMOVE ANY OF THESE DECALS. IF THE DECALS ARE LOST, DAMAGED, OR IF THE MANURE SPREADER IS REPAINTED, REPLACE THE DECALS. REMEMBER: DECALS ARE FOR YOUR PROTECTION AND INFORMATION.

Listed below are the decals on your Manure Spreader. These decals may be ordered individually by part number or by ordering a complete set.

<u>PART #</u>	<u>QTY</u>	<u>DESCRIPTION</u>
311	1	Patent Numbers
1494A	4	Warning - Do Not Operate
1494B	1	Warning - Do Not Remove Shields
1494J	1	Warning - Do Not Clean
1494K	3	Warning - Do Not Remove Shields
1494L	1	Danger - Rotating Driveline
9194A	1	Danger - No Step
9194B	1	Danger - Never Allow Riders
11599	2	Warning - Stay Clear of Leaks (when equipped w/hyd. endgate)
12794	2	Warning - Do Not Remove Shields
54033	1	Made in the U.S.A.
66076	5	Grease Zerk Located Behind Shield
71188B	1	Jack Storage
92180	1	H&S Logo Decal LH Side
92178	1	Model Number LH Side
92181	1	H&S Logo Decal RH Side
92179	1	Model Number RH Side
92183	1	H&S Logo Decal Front
92182	1	Model Number Decal Front
71494A	2	Warning - Do Not Operate
72203A	1	Warning - Help Avoid Injury
72538	1	Warning - Do Not Operate
82602	1	Warning - Crushing Hazard
82793	1	Warning - Disengage PTO before Shifting
84044	1	FEMA
84045	1	H&S Since 1967
081312	1	Grease Zerk Located Behind Sprocket
093020	6	Grease Zerk
11211176	1	Shear Bolts
111593A	2	Danger - Stay Clear of Beater
111593C	2	Warning - Stay Clear of Endgate
DCAMB	4	Amber Reflector
DCRED	2	Red Reflector
98305	1	Decal, Cold Weather Operation

DECAL LOCATION

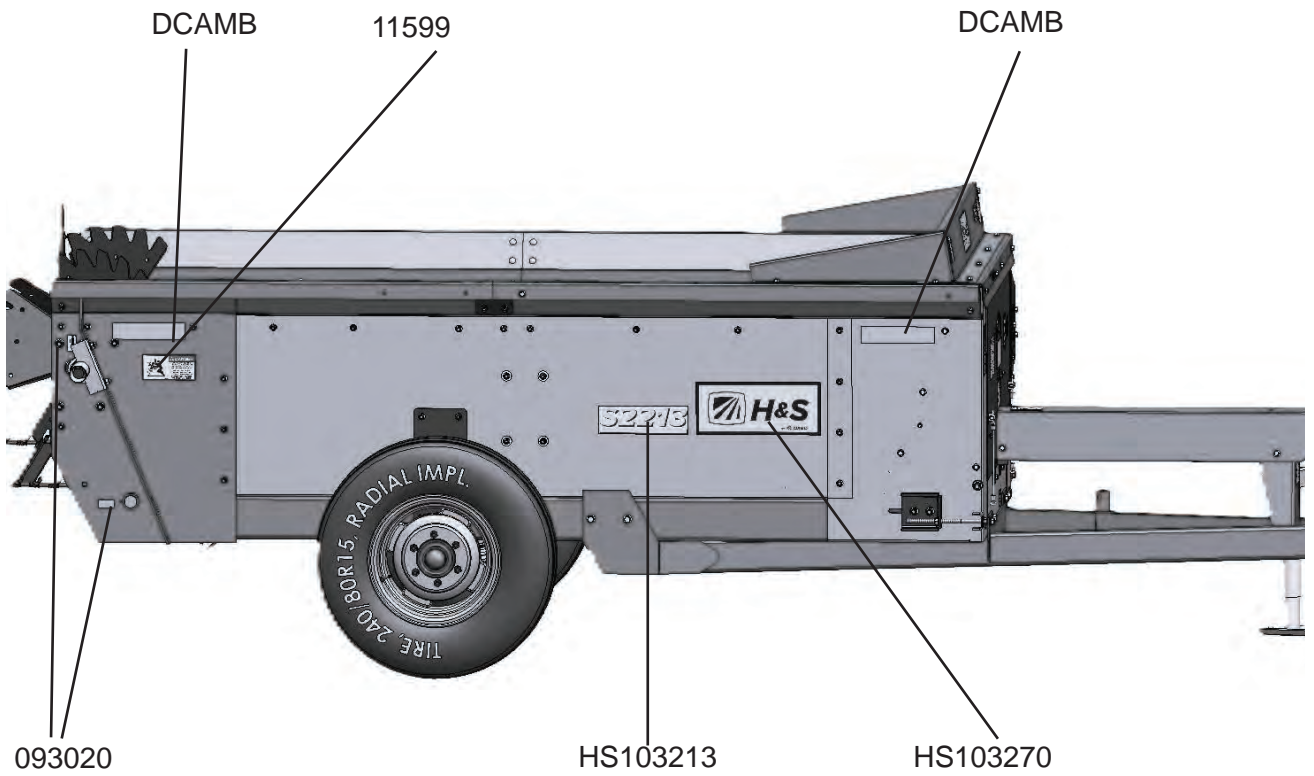
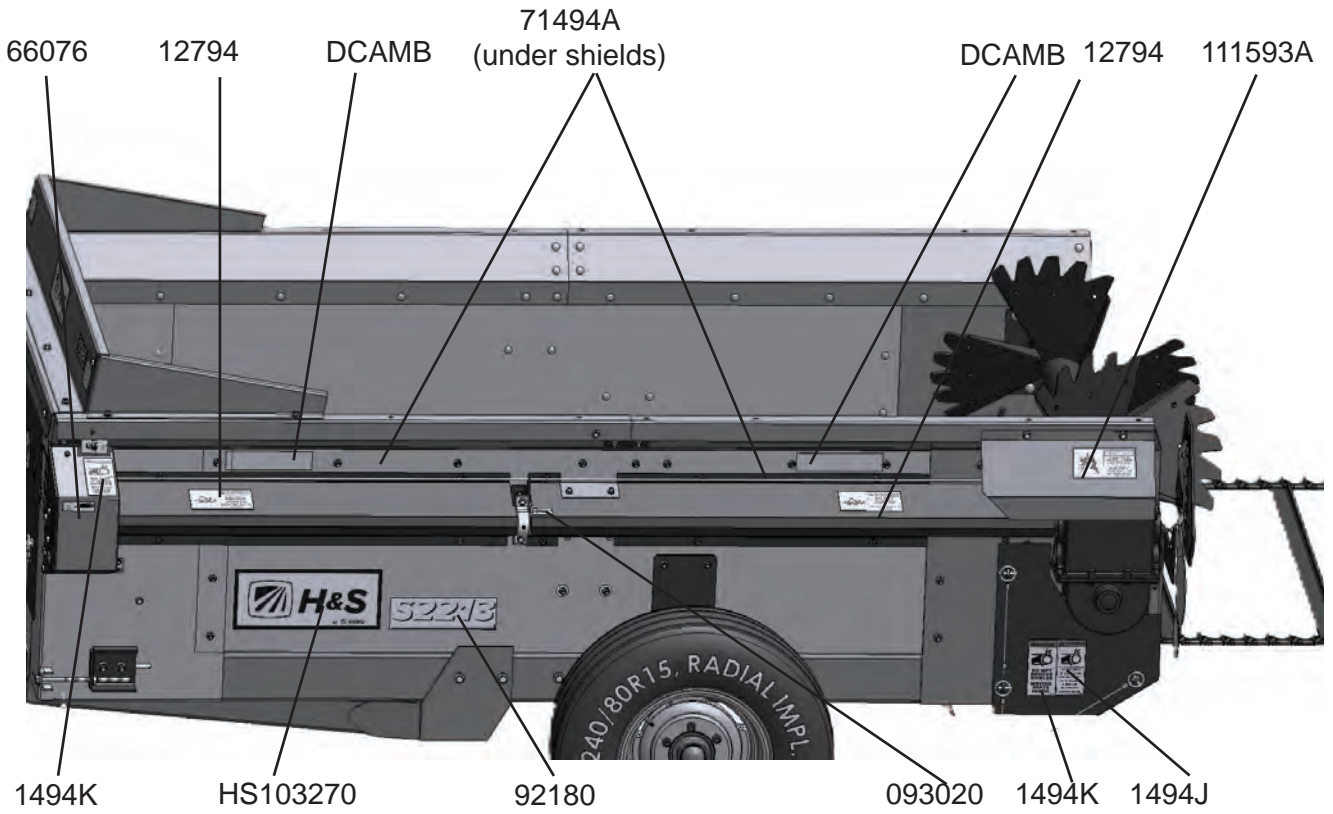

DECAL LOCATION

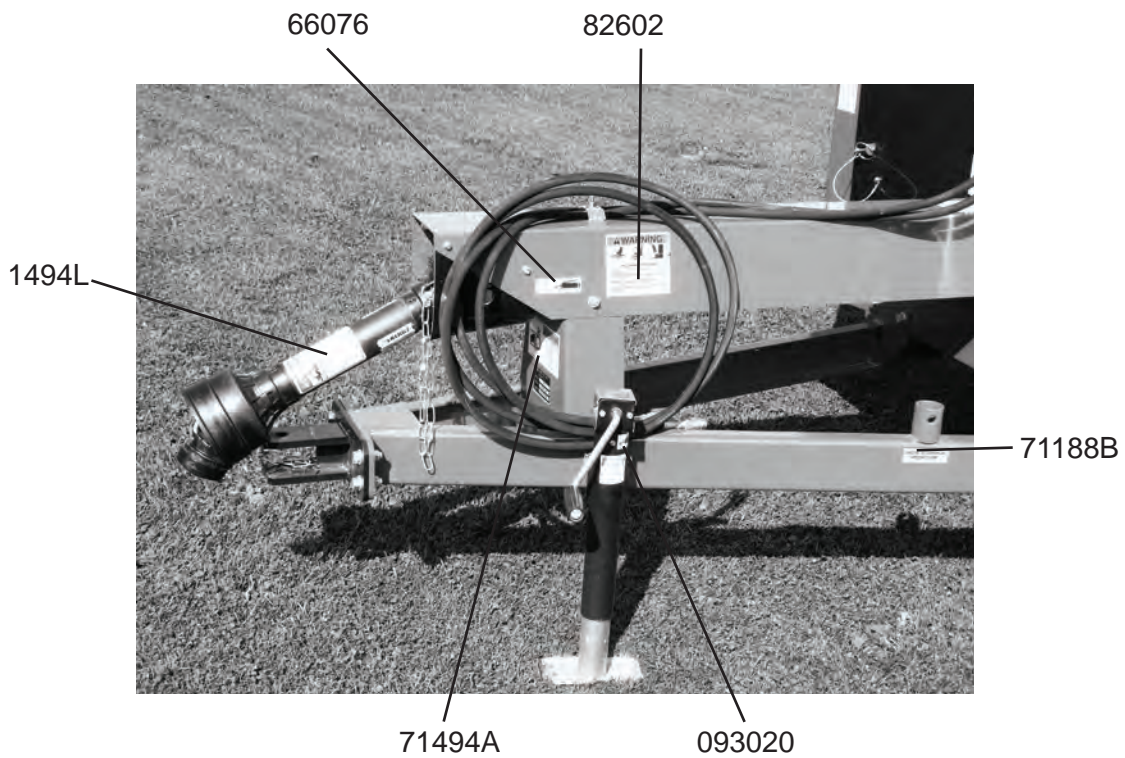
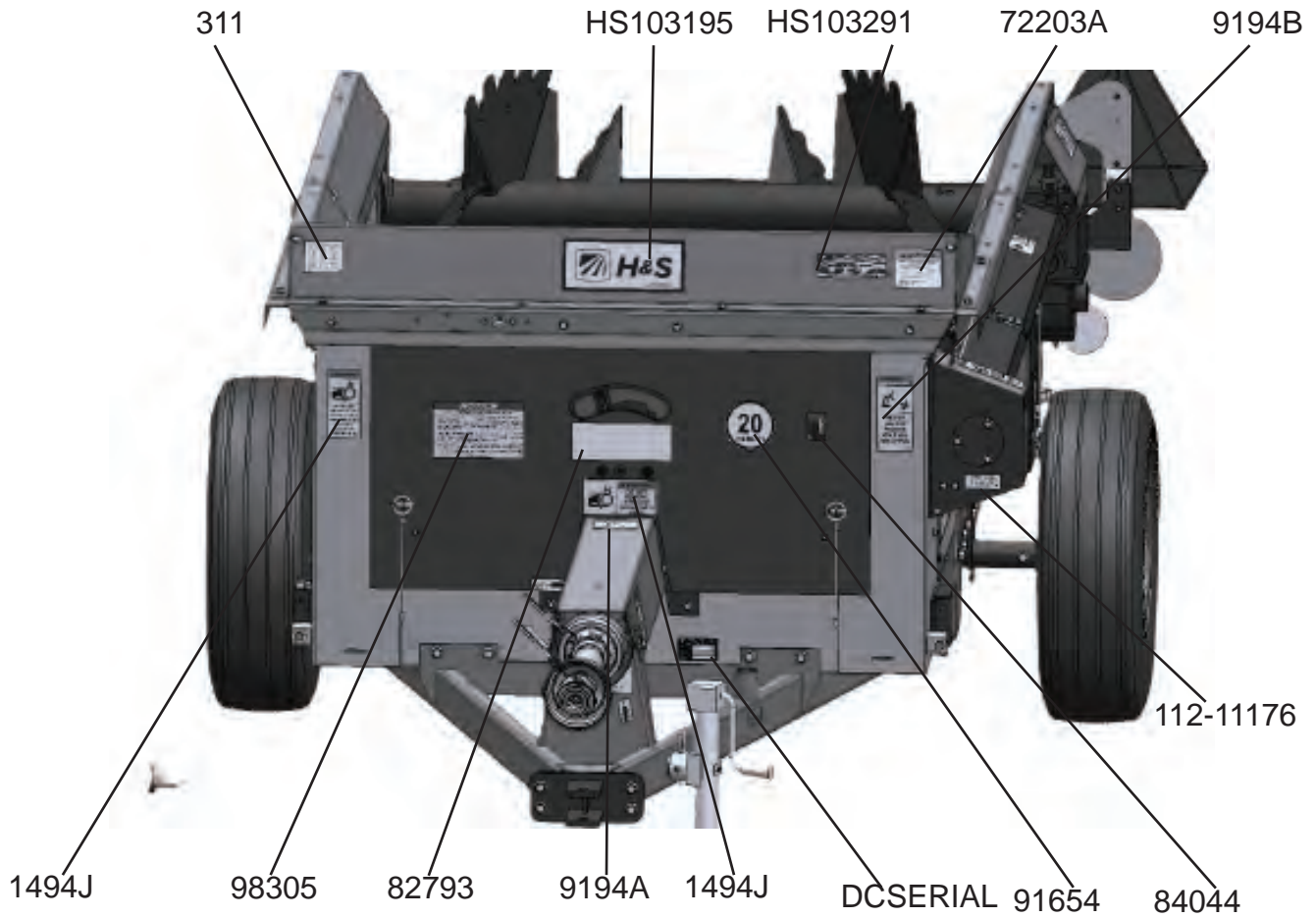

DECAL LOCATION

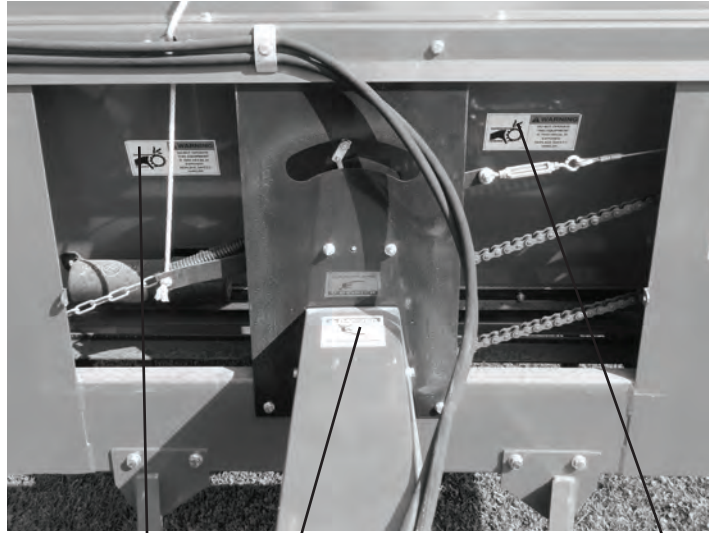

1494A

9194A

1494A



72538

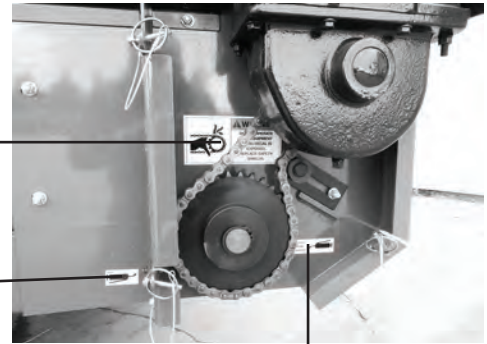

1494A

093020

081312



DCRED

DCRED

TROUBLESHOOTING



WARNING:

MAKE SURE THAT THE TRACTOR IS SHUT OFF AND SPREADER CANNOT MOVE BEFORE SERVICING THE MANURE SPREADER. MAINTENANCE AND REPAIR SERVICE WORK TO BE PERFORMED BY A QUALIFIED SERVICE PERSON ONLY.

TROUBLE...	POSSIBLE CAUSE...	POSSIBLE REMEDY...
Beater Does Not Turn	PTO Not Turning	Engage Tractor PTO
	Beater Not Engaged	Engage Beater-stop pto and shift low.
	Shear Bolt Sheared	Replaced Shear Bolt
	Front Drive Chain Off, Broken, or Missing	Replace or Repair Front Drive Chain
	Beater to Gear Box Attaching Bolts Sheared or Missing	Replace Sheared or Missing Beater Bolts
	Beater Drive Sprocket Key Sheared or Missing	Replace Sheared or Missing Key
Beater Will Not Disengage	Beater Engage/Disengage Cable Stretched or Broken	Re-adjust or Replace Cable
Apron Does Not Turn	PTO Not Turning	Engage Tractor PTO
	Shear Bolt Sheared	Replace Shear Bolt
	Front Drive Chain Off, Broken, or Missing	Replace or Repair Front Drive Chain
	Main Apron Broken	Replace or Repair Main Apron
	Keys on Main Apron Shaft Sheared or Missing	Replace Sheared or Missing Keys

H&S MFG. CO.

products approved

for the

FEMA

SEAL OF QUALITY



Manufactured by:

H&S MANUFACTURING CO., INC.

2608 S. HUME AVE. MARSHFIELD, WI 54449

(715) 387-3414 | hsmfgco.com

