



OPERATOR'S MANUAL

**HDB9215
LOADMASTER X**

**Part #89764
Rev. #03
HSMFG021025**

Starting Ser. # 521HDB1516

CONTENTS

Warranty	1
Manufacturer's Statement	2
Warranty Registration Form	3
Dealer Pre-Delivery Checklist	5
Dealer Delivery Checklist	7
Be Alert Symbol	9
Explanation of Safety Signs	10
Safety Decals	11
Warning - Owner Must Read and Understand	12
Cap Screw Torque Values	13
Hydraulic Fitting Torque Specifications	14-15
Set-Up & Assembly	16
Preparing for Operation	17
Transporting	17
Operation	18
Service	19
Storage	19
Optional Equipment	20
Lubrication Guide	21-22
Decal Location & Identification	23-26
Troubleshooting	27
Service Notes	28

H&S WARRANTY

H&S Manufacturing Co., Inc. ("H&S") warrants this product to be free from defect in material and workmanship. Except as noted below, this warranty term is twelve (12) months on parts and labor, and twenty-four (24) months on parts only from the date of delivery of the product to the original purchaser by an authorized H&S dealer. Under this warranty, H&S will repair or replace, at its option, any covered part which is found to be defective in material or workmanship during the applicable warranty term. In no case will the covered repair cost of a part or parts exceed the replacement cost of that part. In no case, unless pre-authorized by H&S, will a component be replaced versus repaired unless the cost of labor and parts exceeds 75% of the cost of a new component. Warranty repairs must be performed by H&S or a dealer authorized by H&S to sell and/or service the product involved, and will use only new or remanufactured parts or components furnished by H&S. Any warranty repairs needing to be performed by a third party must be pre-authorized by H&S. Standard freight costs will be covered by H&S for any part used to make a warrantable repair, any form of express freight will not be covered unless pre-authorized by H&S. This warranty includes approved parts and labor to repair the product but does not include, and the purchaser is responsible for, any service call and/or transportation of the product to and from the dealer's place of business, for any costs related to travel, for any premium charged for overtime labor requested by the purchaser, and for any service work not directly related to any defect covered under this warranty. This warranty includes only those components of the product manufactured by H&S. Warranty for any component not manufactured by H&S including, but not limited to, engines, batteries, tires, rims, hydraulic motors, pumps, etc. are covered by the warranty, if any, provided separately by their respective manufacturers. H&S reserves the right to request the return

This warranty in all its parts is extended solely to the original purchaser of the product, is terminated upon any subsequent transfer or sale from or by the original purchaser, and extends no third party benefits or rights whatsoever.

The warranty term for any product used in any for hire, rental fleet or rental application, is limited to six (6) months from the date of delivery of the product to the original purchaser by an authorized H&S dealer.

This warranty does not include: (1) Any product that has been altered or modified in ways not approved by H&S; (2) Depreciation or damage caused by normal wear, use for which the product was not designed, misuse, improper or insufficient maintenance, improper operation, accident or failure to follow the product Operator's Manual recommendations and product decal recommendations; (3) Normal maintenance parts and service; (4) Repairs made with parts other than those available from H&S or performed by anyone other than H&S or a dealer authorized by H&S to sell and/or service the product involved.

To secure warranty service the purchaser must report the product defect to a dealer authorized by H&S to sell and/or service the product involved within the applicable warranty term together with evidence of the warranty start date and make the product available to that dealer within a reasonable period of time.

For these warranty terms to be in effect the selling authorized H&S dealer and/or the customer must submit the warranty registration to H&S.

THERE ARE NO WARRANTIES WHICH EXTEND BEYOND THE DESCRIPTION ON THE FACE OF THIS WARRANTY. H&S and the companies affiliated with it make no warranties, representations, or promises, express or implied, as to the performance or freedom from defect of its products other than those set forth above and NO IMPLIED WARRANTY OF MERCHANTABILITY, FITNESS OR FITNESS FOR A PARTICULAR PURPOSE IS MADE. IN NO EVENT WILL THE DEALER, H&S OR ANY COMPANY AFFILIATED WITH H&S BE LIABLE FOR INCIDENTAL OR CONSEQUENTIAL DAMAGES. The ONLY REMEDY the purchaser has in connection with the breach of performance of any warranty on H&S products are those set forth above.

The selling dealer has no authority to make any representation or promise on behalf of H&S, or to modify the terms or limitations of this warranty in any way.

12/20/22

MANUFACTURER'S STATEMENT

Congratulations on your selection of an H&S product. Your new H&S product has been manufactured of the finest quality materials and components. The performance you receive from your machine is largely dependent upon how well you read, understand this manual, and apply this knowledge. There is a right and a wrong way to do everything. Please do not assume that you know how to operate and maintain your machine before reading this manual carefully. Keep this manual available for ready reference. We are very appreciative of your patronage.

H&S reserves the right to make changes or add improvements to its products at any time without incurring any obligation to make such changes to products previously manufactured. Specifications, statements and descriptions of Products contained in this publication are subject to change without prior notification.

WARRANTY REGISTRATION

- Date of Purchase: _____
- Purchaser Name: _____
Street Address: _____
- City: _____
- State: _____ Zip: _____

- Phone Number: _____
- E-mail Address: _____

Model Number: _____

Serial Number: _____

You have received the Operator's Manual for this product. Yes _____ No _____

Interested in receiving the H&S E-mail Newsletter? Yes _____ No _____

Dealer Name: _____

Street Address: _____

City: _____

State: _____ Zip: _____

Signature: _____

All fields must be filled out to ensure prompt notification of product and/or warranty updates.

-3-

**Please mail the completed WARRANTY REGISTRATION FORM to:
H&S Manufacturing Co., Inc.
2608 S. Hume Ave.
Marshfield, WI 54449**

Intentionally Left Blank

DEALER PRE-DELIVERY CHECKLIST

AFTER COMPLETION, DEALER SHOULD REMOVE AND RETAIN FOR RECORDS

After the **HI-DUMP** has been completely set up, check to be certain it is in correct operating order before delivering to the customer. The following is a list of points to inspect. Check off each item as you have made the proper adjustments and found the item operating satisfactorily.

- HI-DUMP** was not damaged in shipment. Check for dents and loose or missing parts. Report damage immediately to H&S Manufacturing Co., Inc.
- HI-DUMP** has been correctly assembled according to the Dealer Set-up Instructions and/ or the Set-up & Assembly Instructions in this manual.
- Wheel nuts are torqued to listed specification and all other fasteners are tightly secured.
- All bolts and fasteners are tight.
- All shields and guards are in place and fastened.
- All grease fittings have been lubricated.
- Hoses and fittings are properly attached and there are no visible leaks.
- All cylinder/mechanisms are operating trouble free.
- Decals are in place and legible.
- For proper weight ballast, a tractor weight kit & weights, or solution in excess of 1,600 lbs. has been added to the tire opposite the dump side.

Model Number _____

Serial Number _____

Dealer's Name _____

Inspection Date _____

Signature of Pre-Delivery Inspector _____

(Remove Dealers File Copy At Perforation)

Intentionally Left Blank

DEALER DELIVERY CHECKLIST

AFTER COMPLETION, DEALER SHOULD REMOVE AND RETAIN FOR RECORDS

This checklist that follows is an important reminder of valuable information that should be passed on to the customer at the time this **HI-DUMP** is delivered.

Check off each item as you explain it to the customer.

This delivery checklist, when properly filled out and signed assures the customer that the Pre-delivery service was satisfactorily performed.

- Explain to the customer that the pre-delivery inspection was made.
- Explain to the customer all the safety precautions they must exercise when operating this unit.
- Explain the capacity constraints of GVWR rating of approximately 45,000 lbs. for the **HI-DUMP**.
- Explain to customer that regular lubrication is required for proper operation and long life of the machine.
- Show customer the lubrication section of Owner's Manual.
- Give the customer Operator's Manual and make sure they read and understand all operating and service instructions.

Date Delivered _____

Dealer's Name _____

By _____

Signature of Original Buyer _____

Note: Warranty is not valid until warranty card is completed and returned to H&S Mfg. Co., Inc.

Intentionally Left Blank

SAFETY INFORMATION



**BE
ALERT!**

**YOUR SAFETY
IS INVOLVED.**

THIS SYMBOL IS USED THROUGHOUT THIS BOOK WHENEVER YOUR PERSONAL SAFETY IS INVOLVED. TAKE TIME TO BE CAREFUL. REMEMBER: THE CAREFUL OPERATOR IS THE BEST OPERATOR. MOST ACCIDENTS ARE CAUSED BY HUMAN ERROR. CERTAIN PRECAUTIONS MUST BE OBSERVED TO PREVENT THE POSSIBILITY OF INJURY OR DAMAGE.

H&S MANUFACTURING CO. INC.

SAFETY INFORMATION

Keep signs in good condition. Immediately replace any missing or damaged signs.

RECOGNIZE SAFETY INFORMATION

This is the safety alert symbol. When you see this symbol on your machine or in this manual, be alert to the potential for personal injury.

Follow recommended precautions and safe operating practices.



UNDERSTAND SIGNAL WORDS

A signal word - DANGER, WARNING, or CAUTION - is used with the safety alert symbol. DANGER identifies the most serious hazards.

Safety signs with signal word DANGER or WARNING are typically near specific hazards.

General precautions are listed on CAUTION safety signs.



WARNING



CAUTION



FOLLOW SAFETY INSTRUCTIONS

Carefully read all safety messages in this manual, and all safety signs on your machine. Follow all recommended precautions and safe operating procedures.

OBSERVE MAXIMUM TRANSPORT SPEED

The maximum transport speed for this implement is 32 km/h (20 mph).

Some tractors are capable of operating at speeds that exceed the maximum transport speed of this implement. Regardless of the maximum speed capability of the tractor being used to tow this implement, do not exceed the implement's maximum transport speed.

Exceeding the implement's maximum transport speed can result in:

- Loss of control of the tractor/implement combination
- Reduced or no ability to stop during braking
- Implement tire failure
- Damage to the implement structure or its components

Use additional caution and reduce speed when towing under adverse surface conditions, when turning, and when on inclines.

Do not attempt transport if the fully loaded implement weighs more than 1.5 times the weight of the tractor.



SAFETY INFORMATION



⚠ WARNING

DO NOT GO NEAR LEAKS

- High pressure oil easily punctures skin causing serious injury, gangrene or death.
- If injured, seek emergency medical help. Immediate surgery is required to remove oil.
- Do not use finger or skin to check for leaks.
- Lower load or relieve hydraulic pressure before loosening fittings.

11599



⚠ WARNING

RUN-AWAY/BREAK-AWAY HAZARD

TO PREVENT SERIOUS INJURY OR DEATH:

SHIFT TO LOWER GEAR BEFORE GOING DOWN STEEP GRADES. KEEP TOWING VEHICLE IN GEAR AT ALL TIMES.

NEVER EXCEED A SAFE TRAVEL SPEED.

ALWAYS USE SAFETY PIN WITH LOCKING DEVICE AND SAFETY CHAIN WHEN ATTACHING TOWING VEHICLE.

1495A



⚠ DANGER

MAINTAIN SAFE CLEARANCE FROM ELECTRICAL POWER LINES AND AVOID CONTACT WITH ANY ELECTRICALLY CHARGED CONDUCTOR.

CONTACT WITH ELECTRIC POWER SOURCES CAN RESULT IN ELECTRICAL SHOCK OR ELECTROCUTION.

FAILURE TO HEED THIS WARNING MAY RESULT IN SERIOUS INJURY OR DEATH.

1494P

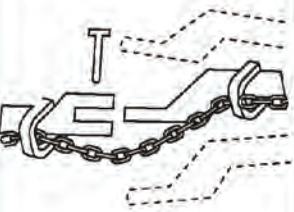

⚠ CAUTION

TOWING HAZARD

To Avoid Injury or Machine Damage

- Install safety chain when attaching to tractor.
- Use a safety chain with tensile strength equal to or greater than the gross weight of the machine.
- Provide only enough stack for turning.



⚠ DANGER

OVERHEAD LIFT HAZARD

MECHANICAL OR HYDRAULIC FAILURE CAN ALLOW BOX TO FALL RAPIDLY.

To Prevent Serious Injury or Death!

- Stand clear of machine when box is raising, dumping and/or lowering.
- Keep others away.

89078



⚠ WARNING

CRUSHING HAZARD

TO PREVENT SERIOUS INJURY OR DEATH:

KEEP HANDS AND BODY OUT OF HITCH AREA WHEN ATTACHING TOWING VEHICLE.

KEEP BODY CLEAR OF CRUSH POINT BETWEEN TOWING VEHICLE AND LOAD.

KEEP FEET AND LEGS CLEAR FROM UNDER TONGUE AREA IN CASE OF POSSIBLE JACK FAILURE.

82602

⚠ WARNING

TO PREVENT SERIOUS INJURY OR DEATH:

READ AND UNDERSTAND OWNER'S MANUAL BEFORE USING. REVIEW SAFETY PRECAUTIONS ANNUALLY.

DO NOT EXCEED 10 MPH WHEN GROSS TOWED LOAD WEIGHS MORE THAN THE TOWING VEHICLE. IF GROSS TOWED LOAD WEIGHS LESS THAN THE TOWING VEHICLE, MAXIMUM TOWING SPEED IS 20 MPH.

DO NOT TOW WAGONS IN TANDEM ON PUBLIC ROADS.

DO NOT OPERATE ON PUBLIC ROADS UNLESS PROPER LIGHTS AND REFLECTORS ARE INSTALLED AND WORKING.

DO NOT USE THIS RUNNING GEAR TO HAUL ANHYDROUS AMMONIA OR OTHER PRESSURIZED TANKS.

DO NOT ALLOW RIDERS ON MACHINE.

DO NOT OVERLOAD.

DO NOT EXCEED RATED CAPACITY OF WHEEL AND TIRE COMBINATION USED.

MAINTAIN WHEEL BOLTS AT TORQUE RECOMMENDED IN OPERATOR'S MANUAL.

BEFORE MAINTENANCE OR REPAIR STOP TOWING VEHICLE, SET PARKING BRAKE, AND REMOVE IGNITION KEY.

PLACE SAFETY STANDS UNDER FRAME AND CHOCK WHEELS BEFORE WORKING ON TIRES OR RUNNING GEAR.

IF EQUIPPED WITH BRAKES, MAINTAIN PROPER ADJUSTMENT.

91604

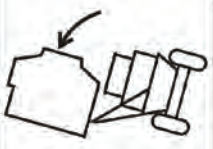

⚠ WARNING

TIPPING HAZARD

To Prevent Injury or Machine Damage.

ADD FLUID TO TIRES ON THIS SIDE

89079

⚠ WARNING

HELP AVOID INJURY

- READ & UNDERSTAND THE OPERATORS MANUAL PROVIDED WITH THIS MACHINE. IF MISPLACED CALL H & S MANUFACTURING AT 715-387-3414 WITH MODEL AND SERIAL NUMBER.
- UNDERSTAND ALL SAFETY WARNINGS AND FUNCTION OF CONTROLS.
- KEEP SAFETY DEVICES IN PLACE AND WORKING.
- KEEP YOURSELF AND OTHERS WELL CLEAR OF MOVING PARTS.
- DISCONNECT ALL POWER BEFORE SERVICING OR CLEANING THIS MACHINE.
- DO NOT EXCEED 20 MPH

72203A



⚠ WARNING

TIPPING HAZARD

TO PREVENT INJURY OR MACHINE DAMAGE

- DO NOT DUMP WITH LOAD AT ONE END.
- DO NOT DUMP UNLESS WAGON IS ON LEVEL GROUND.
- DO NOT DUMP WITH A LOW OR FLAT TIRE.
- DO NOT MOVE WAGON WHEN BOX IS ELEVATED.
- DO NOT EXCEED LOAD CAPACITY
- FOR PROPER WAGON BALLAST ADD FLUID TO TIRE OPPOSITE THE DUMP SIDE

89080

⚠ CAUTION



PINCH POINT

51010

⚠ CAUTION!

NO STEP

STAY CLEAR

106-4176

SAFETY INFORMATION



WARNING

TO PREVENT SERIOUS INJURY OR DEATH

BEFORE YOU ATTEMPT TO OPERATE THIS EQUIPMENT, READ AND STUDY THE FOLLOWING INFORMATION. IN ADDITION, MAKE SURE THAT EVERY INDIVIDUAL WHO OPERATES OR WORKS WITH THIS EQUIPMENT, WHETHER FAMILY MEMBER OR EMPLOYEE, IS FAMILIAR WITH THESE SAFETY PRECAUTIONS. KNOW HOW TO STOP UNLOADING MECHANISM BEFORE STARTING IT.

If the machine needs repair, disengage hydraulics, stop the engine, remove ignition key and allow all mechanisms to stop before cleaning or working on the machine.

DO NOT ALLOW PERSONNEL OTHER THAN QUALIFIED OPERATOR NEAR THE MACHINE.

DO NOT attempt to perform maintenance or repair with tractor running and hydraulics hooked to the power source.

DO NOT step up on machine at any time.

DO NOT leave tractor cab when box is in operation.

DO NOT allow minors to operate or be near machine.

STAY CLEAR of rear of the **HI-DUMP** at all times.

DO NOT clean, adjust, or lubricate the machine when any part is in operation.

BE SURE the machine is clear of people, tools, and any other objects before engaging hydraulics.

NEVER operate the **HI-DUMP** until all guards and safety shields are secured in place.

STAY CLEAR of hydraulic lines, they may be under extreme pressure or heat.

CAUTION - Beware of low electrical wires.

Loose or floppy clothing should not be worn by the operator.

Securely support any machine elements that must be raised for assembly, repair, or adjustments. Use caution when working under or near these areas.

After assembling, repairing or adjusting, make sure all tools, parts, and rags are removed from the machine before attempting to operate it.

H&S Mfg. Co. always takes the operator and their safety into consideration and guards exposed moving parts for their protection. However, some areas cannot be guarded or shielded in order to ensure proper operation. In addition, the Operator's Manual and decals on the machine itself warn you of further danger and should be read and observed closely.

Study The Above Safety Rules

ATTENTION - BE ALERT - YOUR SAFETY IS INVOLVED

CAP SCREW TORQUE VALUES

The specifications below are the torque values for fasteners as it adheres to the SAE torque value standards. All fasteners should be torqued to the proper values found in the figures below unless otherwise specified by the engineering drawing.

- Lubed torque would be any fastener that has grease, liquid Loctite, oil, etc. on the threads.
- Dry torque would be any fastener which has threads that are clean and dry and do not have any liquid Loctite or grease on them.

Hex Head Fasteners

The figure shown below shows how to determine what SAE grade a fastener is.

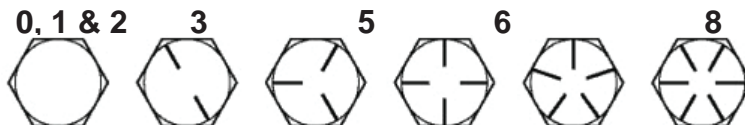

SUGGESTED ASSEMBLY TORQUE VALUES							WORKING TORQUE			
	SAE GR. 2-6"		SAE GR. 5		SAE GR. 8		18-8 SS	316 SS	Brass	Silicon Bronze
Dia. & Thrds. per inch	Dry Ft. Lbs.	Lube Lbs.	Dry Ft. Lbs.	Lube Lbs.	Dry Ft. Lbs.	Lube Lbs.	Inch Lbs.	Inch Lbs.	Inch Lbs.	Inch Lbs.
1/4-20	5.5	4.2	8	6.3	12	9	75.2	78.8	61.5	68.6
1/4-28	6.3	4.7	10	7.2	14	10	94.0	99.0	77.0	87.0
5/16-20	11	8	17	13	24	18	132	138	107	123
5/16-28	12	9	19	14	27	20	142	147	116	131
3/8-16	20	15	30	23	45	35	236	247	192	219
3/8-24	23	17	35	25	50	35	259	271	212	240
7/16-14	32	24	50	35	70	50	376	393	317	349
7/16-20	36	27	55	40	80	60	400	418	327	371
1/2-13	50	35	75	55	110	80	517	542	422	480
1/2-20	55	40	85	65	120	90	541	565	443	502
9/16-12	70	55	110	80	150	110	682	713	558	632
9/16-18	80	60	120	90	170	130	752	787	615	697
5/8-11	100	75	150	110	210	160	1110	1160	907	1030
5/8-18	110	85	170	130	240	180	1244	1301	1016	1154
3/4-10	175	130	260	200	380	280	1530	1582	1249	1416
3/4-16	200	140	300	220	420	310	1490	1558	1220	1382
7/8-9	170	125	430	320	600	450	2328	2430	1905	2140
7/8-14	180	140	470	350	670	500	2318	2420	1895	2130
1-8	250	190	640	480	910	680	3440	3595	2815	3185
1-14	280	210	720	540	1020	760	3110	3250	2545	2885

HYDRAULIC FITTING TORQUE SPECIFICATIONS

Tapered Pipe Thread Size - Assembly turns from Finger Tight (TFFT) for Tapered Threads		TFFT
BSPT (Uncommon)	NPTF (Common)	
1/8-28	1/8-27	2 - 3
1/4-19	1/4-18	2 - 3
3/8-19	3/8-18	2 - 3
1/2-14	1/2-14	2 - 3
3/4-14	3/4-14	2 - 3
1-11	1-11 1/2	1.5 - 2.5
1 1/4-11	1 1/4-11 1/2	1.5 - 2.5
1 1/2-11	1 1/2-11 1/2	1.5 - 2.5
2-11	2-11 1/2	1.5 - 2.5



ORB - SAE J1926 Straight Thread Port Assembly Torques															
Assembly Torque (+10% -0) **If fitting is being torqued into aluminum or brass, subtract 35% from standard torque value**															
Dash Size		SAE Size (UN/UNF)		Non-Adjustable				Adjustable				Plugs			
				ORFS		JIC NPT		ORFS		JIC		Hollow Hex		Hex Head	
		Fl. lbs. (in. lbs.)	Into Alum. Or Brass Fl. lbs. (in. lbs.)	Fl. lbs. (in. lbs.)	Into Alum. Or Brass Fl. lbs. (in. lbs.)	Fl. lbs. (in. lbs.)	Into Alum. Or Brass Fl. lbs. (in. lbs.)	Fl. lbs. (in. lbs.)	Into Alum. Or Brass Fl. lbs. (in. lbs.)	Fl. lbs. (in. lbs.)	Into Alum. Or Brass Fl. lbs. (in. lbs.)	Fl. lbs. (in. lbs.)	Into Alum. Or Brass Fl. lbs. (in. lbs.)		
2	5/16-24	-	-	(85)	(55)	-	-	(80)	(39)	(30)	(19.5)	(85)	(55)		
3	3/8-24	-	-	(155)	(101)	-	-	(100)	(65)	(55)	(36)	(155)	(101)		
4	7/16-20	(310)	(201.5)	(260)	(169)	(180)	(117)	(190)	(117)	(120)	(78)	(260)	(169)		
6	1/2-20	(360)	(234)	(280)	(182)	(360)	(234)	(250)	(162.5)	(170)	(110.5)	(280)	(182)		
8	9/16-18	(420)	(283)	(350)	(227.5)	(420)	(273)	(350)	(227.5)	(410)	(266.5)	(350)	(175)		
8	3/4-16	60	39	(620)	(403)	60	39	(620)	(217)	60	39	(620)	(403)		
10	7/8-14	100	65	85	55	100	65	85	55.25	100	65	85	55		
12	1 1/16-12	135	88	135	88	135	88	135	88	135	88	135	88		
14	1 3/16-12	175	114	175	114	175	114	175	114	175	114	175	114		
16	1 5/16-12	200	130	200	130	200	130	200	130	200	130	200	130		
20	1 5/8-12	260	162.5	260	162.5	260	162.5	260	162.5	260	162.5	260	162.5		
24	1 7/8-12	305	198	305	198	305	198	305	198	305	198	305	198		
32	2 1/2-12	375	244	375	244	375	244	375	244	375	244	375	244		



HYDRAULIC FITTING TORQUE SPECIFICATIONS

Code 61 and 62 Flange Recommended Bolt Torques

Steps to Properly Assemble the Flange Port Clamping Bolts:

1. Inspect components to ensure that male and female port threads and sealing surfaces are free of burrs, nicks and scratches, or any foreign material.
2. Lubricate the O-ring
3. Position flange and clamp halves
4. Place lock washers on bolts and insert through clamp halves
5. Hand tighten bolts.
6. Torque bolts in diagonal sequence in small increments to the appropriate torque level **refer to the table below.



Flange Bolt Tightening Sequence

Code 61						Code 62					
Dash Size	Flange Size	Inch Bolt (SAE J518)	Torque ft. lbs.	Metric Bolt (ISO 6162)	Torque N-m	Dash Size	Flange Size	Inch Bolt (SAE J518)	Torque ft. lbs.	Metric Bolt (ISO 6162)	Torque N-m
8	1/2	5/16-18	17 ± 2	M8	24	8	1/2	5/16-18	17 ± 2	M8	24
12	3/4	3/8-18	31	M10	50	12	3/4	3/8-18	31	M10	50
18	1	3/8-18	31 ± 4.5	M10	50	16	1	7/16-14	52	M12	92
20	1-1/4	7/16-14	52	M12	92	20	1-1/4	1/2-13	77	M14	130
24	1-1/2	1/2-13	77	M12	92	24	1-1/2	5/8-11	155	M16	210
32	2	1/2-13	77	M12	92	32	2	3/4-10	265	M20	400
40	2-1/2	1/2-13	77	M12	92						
48	3	5/8-11	155	M16	210						
56	3-1/2	5/8-11	155	M16	210						
64	4	5/8-11	155	M16	210						
80	5	5/8-11	155	M16	210						

 37° Flare (JIC) Assembly Torques and FFWR					
SAE Dash Size	Thread Size	Assembly Torque (+10%-0)		Tube Connection FFWR	Swivel Nut or Hose Connection FFWR
		In. lb.	ft. lb.		
-2	5/16-24	35	3	-	-
-3	3/8-24	65	5	-	-
-4	7/16-20	155	13	2 1/2	2
-5	1/2-20	165	14	2	2
-6	9/16-18	265	22	2	1 1/2
-8	5/8-16	505	42	2	1 1/2
-10	7/8-14	720	60	1 1/2	1 1/2
-12	1 1/16-12	1000	84	1 1/2	1 1/4
-14	1 3/16-12	1200	100	1 1/2	1 1/4
-16	1 5/16-12	1415	118	1 1/2	1
-20	1 5/8-12	2015	168	1	1
-24	1 7/8-12	2340	195	1	1
-32	2 1/2-12	3180	265	1	1
-40	3-12	-	-	1	1

SET-UP & ASSEMBLY

Note: Determine right and left side of the *HI-DUMP* by viewing it from the rear. If instructions or parts lists call for hardened bolts, refer to Cap Screw Torque Values page to identify.

1. If you are assembling the *HI-DUMP* Box refer to the appropriate assembly instructions.
2. Make sure that all bolts are tightened.
3. Check wheel bolts upon delivery, and periodically thereafter. Wheel bolts should be tightened to 340 ft./lbs. of torque. This torque is needed for the axle to carry its rated capacity.
4. Check the tires for proper air pressure. Manufacturers recommended pressure rating on the tire is 35 PSI maximum.
5. Lubricate the *HI-DUMP* completely. (See Lubrication Chapter in this manual).
6. Check all taillights that they are functioning properly.
7. For proper weight ballast, a tractor weight kit & weights, or solution in excess of 1,600 lbs. has been

PREPARING FOR OPERATION

PREPARING THE *HI-DUMP*

- Properly lubricate the *HI-DUMP* before operating. Refer to the Lubrication Chapter of this manual for locations.
- Inspect the tractor hitch & wagon for fatigue, cracks, loose hardware, etc. before connecting the tongue of the wagon to the towing vehicle with a 2" diameter or larger hitch pin. Do not use an inadequate pin which may bend or break under severe conditions.
- Attach the H&S SC60000 safety chain. Provide only enough slack for turning.
- Clean all hydraulic couplings and connect them to the tractor or towing vehicle.
 - Volume of oil required to operate *HI-DUMP*: 6.2 gallons
 - Recommended pressure: 2250 PSI Min.
- Check wheel bolts upon delivery, and periodically thereafter. Wheel bolts should be tightened to 340 ft./lbs. of torque. This torque is needed for the axle to carry its rated capacity.
- Check the tires for proper air pressure. Refer to the manufacturers recommended PSI rating on the tire.
- Do not operate the wagon near overhead power lines or other obstructions. Electrocutation and or damage to the wagon may occur.
- Operate the box through the lift cycle several times powering it at the end each way to purge the system of air and rephase the system.
- **Be sure to check the oil level in your tractor and add oil after cycling if needed.**

TRANSPORTING

When transporting on the highway or roads;

- An SMV mount bracket is located on the rear of the *HI-DUMP*. Always use a slow-moving vehicle emblem when transporting. Keep the SMV emblem and all reflectors clean and visible to warn other motorists.
- Always rotate the lights to the widest position and use the flashing highway lights when traveling on a road or highway, except where such use is prohibited by law.
- Obey all state and local laws concerning the use of the *HI-DUMP* on public roads.
- KNOW YOUR WEIGHT - Do not pull a machine that does not have brakes at more than 1.5 times the weight of the towing vehicle.
- KNOW YOUR WEIGHT - Do not pull a machine that has brakes at more than 4.5 times the weight of the towing vehicle.
- Always use an H&S SC60000 safety chain. Provide only enough slack in the chain to permit turning. Do not use the safety chain for towing without a pin. Inspect the chain for damage and replace if necessary.
- ASABE Standards state that while transporting any equipment that does not have brakes, the maximum speed should NOT exceed 32 km/h (20 MPH).
- Always check for overhead obstacles during transport. Overall length is 304" Gross weight of the *HI-DUMP* is 15,240 lbs.



OPERATION

UNLOADING/DUMPING THE WAGON

1. When dumping into a truck, or other receiving vehicle, choose a level area, free of obstructions.
2. With the operator in the tractor seat, and all others well clear of the **HI-DUMP**, actuate the “LIFT” hydraulic control valve to raise the box to the desired dumping height.
3. When the desired dumping height has been reached, actuate the “TILT/DUMP” hydraulic control valve to dump the box.
4. After the load is dumped, or the desired amount has been dumped, reverse the control valve to bring the box back to the upright position.
5. Reverse the control valve for the lift cylinders to return the box to the transport position.
6. The entire dumping cycle should take approximately two minutes depending on hydraulic supply

CAUTION:

- **Never move the wagon when the box is raised. This will cause extreme stress on the structural members and may cause failure.**
- **Never operate or dump the wagon with a low or flat tire. Always fill the tires on the non-dumping side (the side opposite the receiving vehicle) with chloride solution or an alternative ballast. Failure to do so will cause instability when dumping the wagon and could cause the wagon to overturn.**

REAR FRAME TOW EYES

Rear Tow Eyes allow you to connect to and pull out a box when stuck. Always connect to both tow eyes when attempting to pull - do **NOT** pull from only one side as the unit could twist and cause damage.



SERVICE

WHEEL HUB

OIL ASSEMBLY - DO NOT GREASE!

Follow the steps below when installing a new seal or adjusting the hub tightness.

1. Wipe the rubber seal with oil before installing.
2. Assemble as shown in the picture.
3. Torque the spindle nut to 110 ft. lbs. while rotating the hub to seat in the bearing assembly.
4. Loosen the spindle nut and re-torque to 70 ft. lbs. while rotating the hub.
5. Loosen the spindle nut to no more than 30 degrees to install the spring pin.
6. With the hub horizontal, remove the plastic cap and fill the hub cavity to the fill line with Casrtol Hyspin VG46 hydraulic oil. Replace the plastic cap.

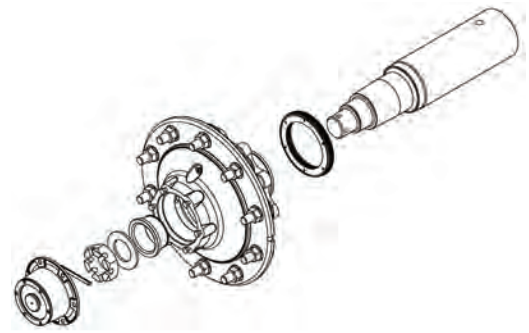

STORAGE

STORAGE AT THE END OF THE YEAR

Rust prevention treatment of the **HI-DUMP** before placing the machine in storage will not only lengthen its useful life, but will assist in maintaining the best possible performance when the machine is put into service next year.

- Clean the entire wagon removing all the dirt and any excessive grease build-up.
- Check the wagon over thoroughly for damaged or worn parts and loose or missing nuts and bolts.
- Replace or repair any part that would cause damage or excessive wear to other parts.
- Touch up any area where the paint has been worn or scratched off the machine.
- Check to see that all the safety decals are intact and readable. Replace any safety decal that is missing or has been scratched or damaged.
- Lubricate the **HI-DUMP** at all points shown in the Lubrication Section of this manual.
- Clean & repack the wheel bearings annually.
- Store the **HI-DUMP** inside if possible.

STARTING NEXT SEASON

- Take the time to read this Operator's Manual to refresh yourself with the safety information and the operating instructions. This time spent could prevent any injury to yourself and also prevent damage to the machine.
- Clean off any dirt or grease that may have accumulated while the wagon was stored. This will prevent any abrasive action that could cause excessive wear.
- After hitching to the tractor, slowly operate the hydraulics to ensure they are working properly.
- Inspect all nuts and bolts for tightness. Make sure all moving parts move freely and do not bind.

OPTIONAL EQUIPMENT

TWP3032R - TIRE & WHEEL PACKAGE

27" x 32" 10 Bolt Wheels w/30.5 x 32 R1 16 Ply Tires

HDO18DLE - EXTENSION KIT

18" Dumping Lip Extension w/18" Front & Rear Flares

HDO2WB - WEIGHT BOX PACKAGE

Dual Weight Box Package include 2 weight boxes w/brackets.

HDBOWBW - WEIGHT BRACKET

(1) WEIGHT BRACKET FOR WEIGHTS W/HARDWARE

HDBO10W - WEIGHTS

(10) SUITE CASE WEIGHTS TO FIT HDBOWBW WEIGHT BRACKET

SC60000 - SAFETY CHAIN

60,000# Safety Chain

LUBRICATION GUIDE

Become familiar with all lubrication points and establish a systematic routine to ensure complete and quick lubrication of the machine.

GENERAL INFORMATION

IMPORTANT: *Catch and dispose of fluid per local waste disposal regulations whenever service is performed on hydraulic components, valves, cylinders, hoses, etc.*

Grease Zerks

Grease as needed during normal use. Also grease **before, after storage, and after power washing.** Use a high-quality grease.

Listed are the location and quantity of zerks.

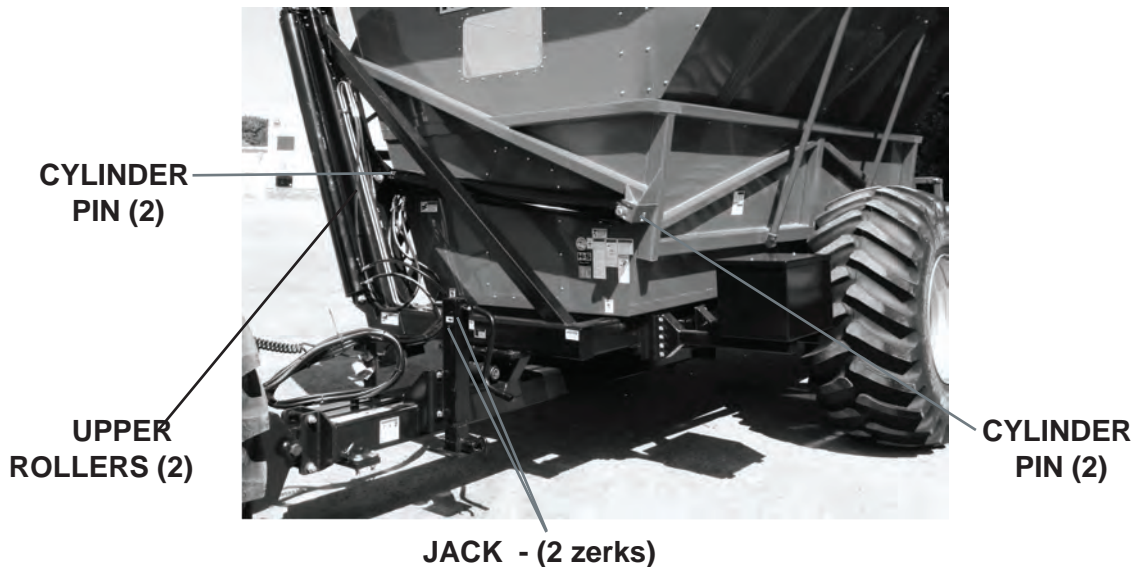

With the hub horizontal, remove the plastic cap and fill the hub cavity to the fill line with Casrtol Hyspin VG46 hydraulic oil. Replace the plastic cap.

LUBRICATION GUIDE



**Slide
Extension
Roller (1)**

**Remote Zerks
* Box Pivots (7)**

**Slide
Extension
Roller (1)**

DECAL LOCATION

Your H&S *HI-DUMP* was manufactured with operator safety in mind. Located on the *HI-DUMP* are various decals to aid in operation and warn of caution areas. Pay close attention to all decals.



DO NOT REMOVE ANY OF THESE DECALS. IF DECALS ARE LOST, DAMAGED, OR IF THE *HI-DUMP* IS REPAINTED, REPLACE DECALS. REMEMBER: DECALS ARE FOR YOUR PROTECTION AND INFORMATION.

Listed below are the decals on your *HI-DUMP* Box.

<u>Part #</u>	<u>Quantity</u>	<u>Description</u>
311	1	Patent Decal
1494P	2	Danger - Maintain Safe Clearance from Electrical Power Lines
1495A	1	Warning Runaway/Breakaway
11599	4	Warning - Do not go near leaks
51010	10	Pinch Point
54034	1	Made In U.S.A.
72203A	1	Warning - Help Avoid Injury
82602	2	Warning - Crushing Hazard
84044	1	FEMA Decal
84045	1	H&S Since 1967 Decal
89078	2	Danger - Overhead Lift Hazard
89079	2	Warning - Tipping Hazard/Solution
89080	6	Warning - Tipping Hazard/Machine Damage
89081	1	Caution - Towing Hazard
94532	2	Loadmaster Decal - Front and Back
94529	1	Loadmaster Decal Right & Left Side
94238	1	H&S Decal Left Side
89819	1	Important - Solution Plastic Tag
89822	2	Important - Wheel Torque
91604	1	Warning - To Prevent Serious Injury or Death
093020	11	Grease Zerk Decal
1064176	4	Caution - No Step/Stay Clear
DCAMB	8	Amber 2 x 9 Reflective

DECAL LOCATION

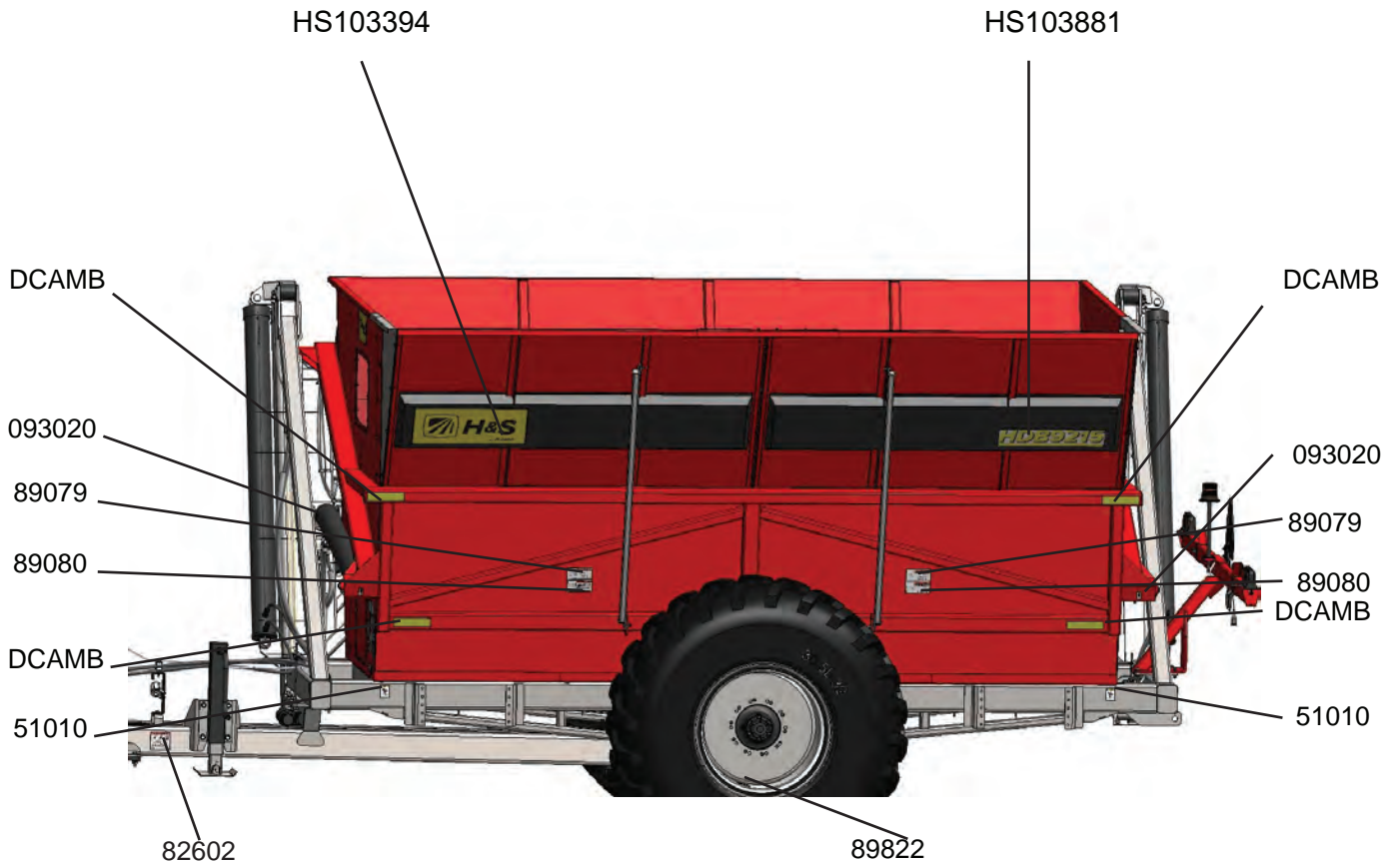
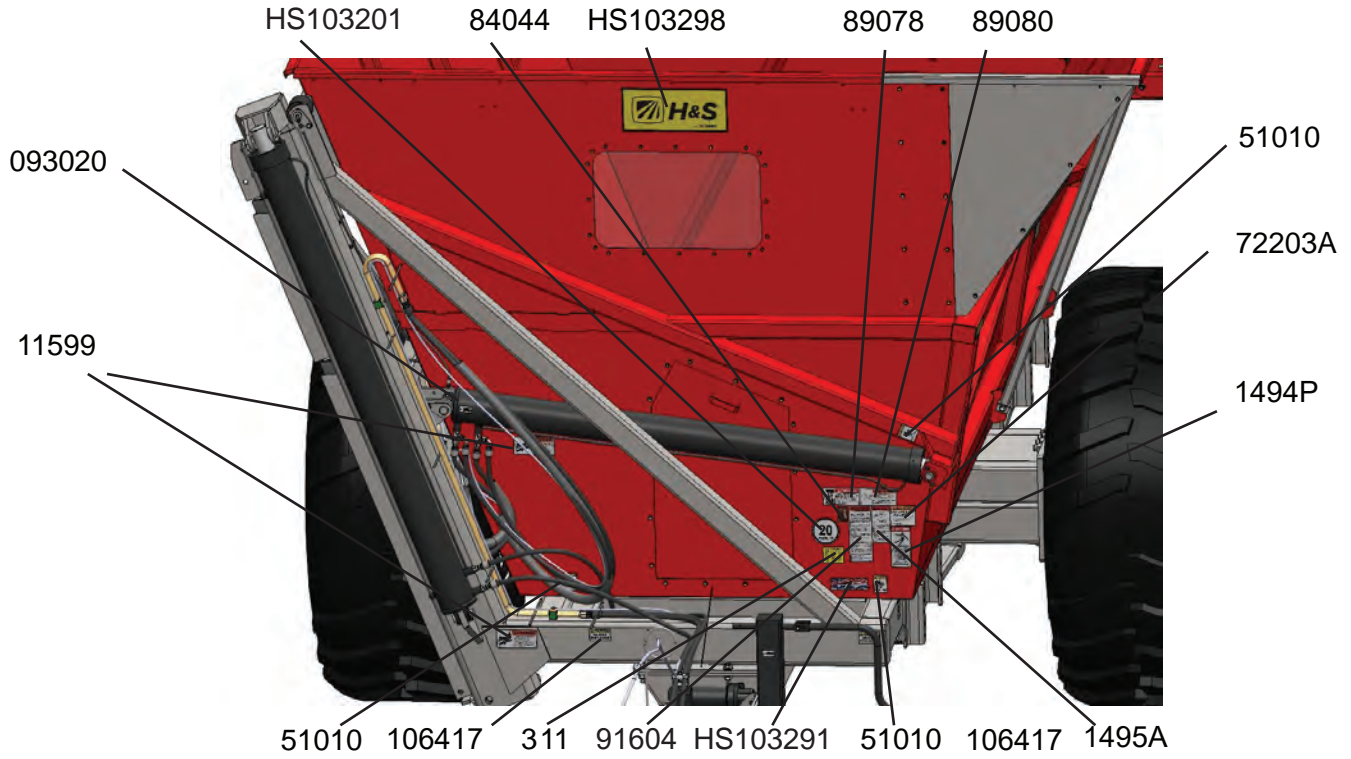

DECAL LOCATION

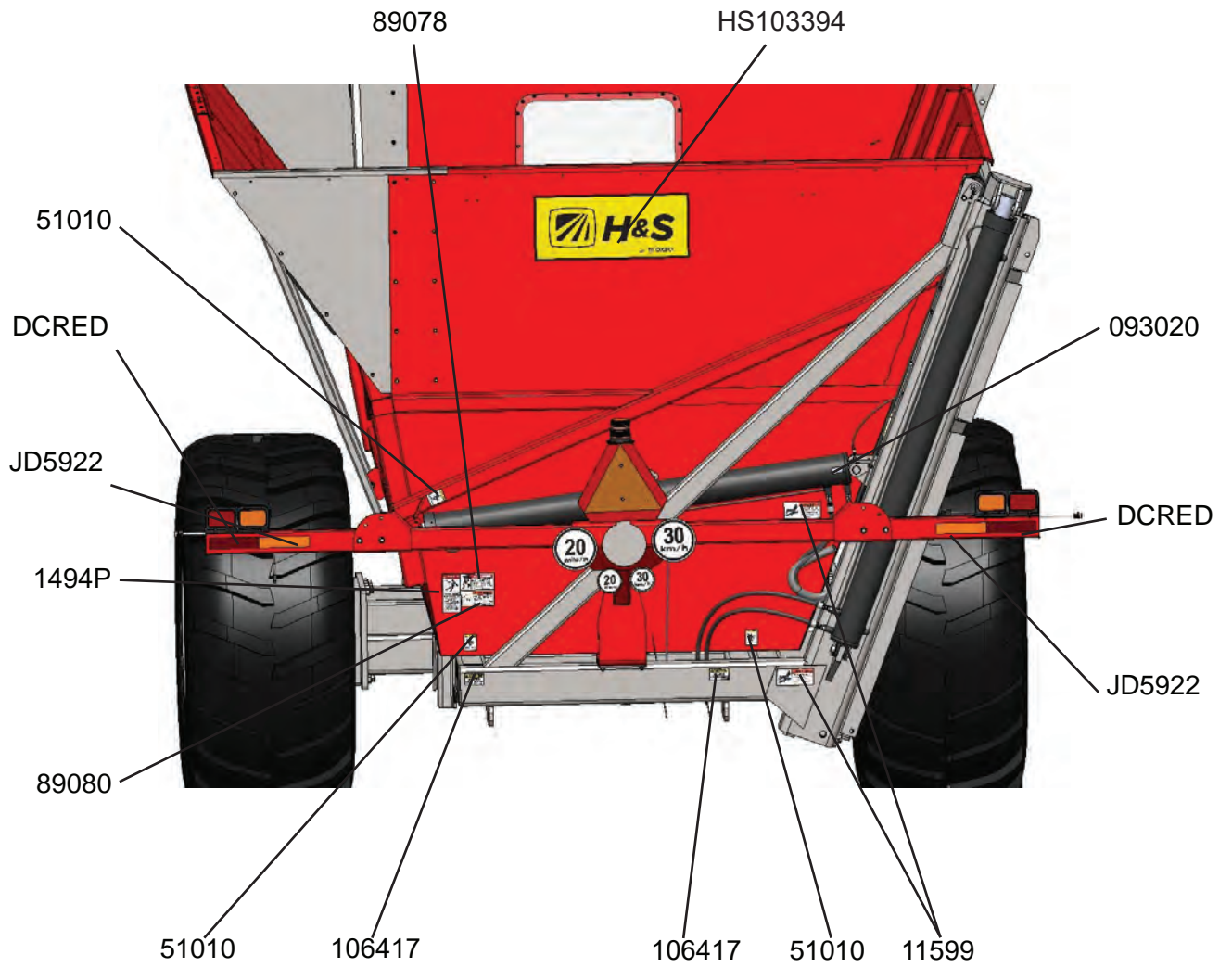

DECAL LOCATION

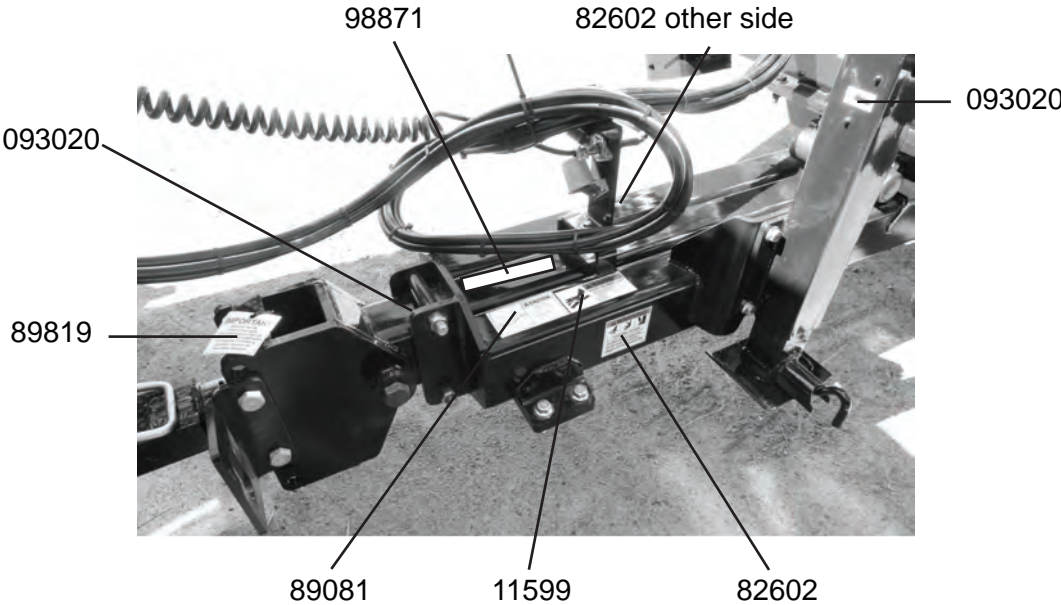
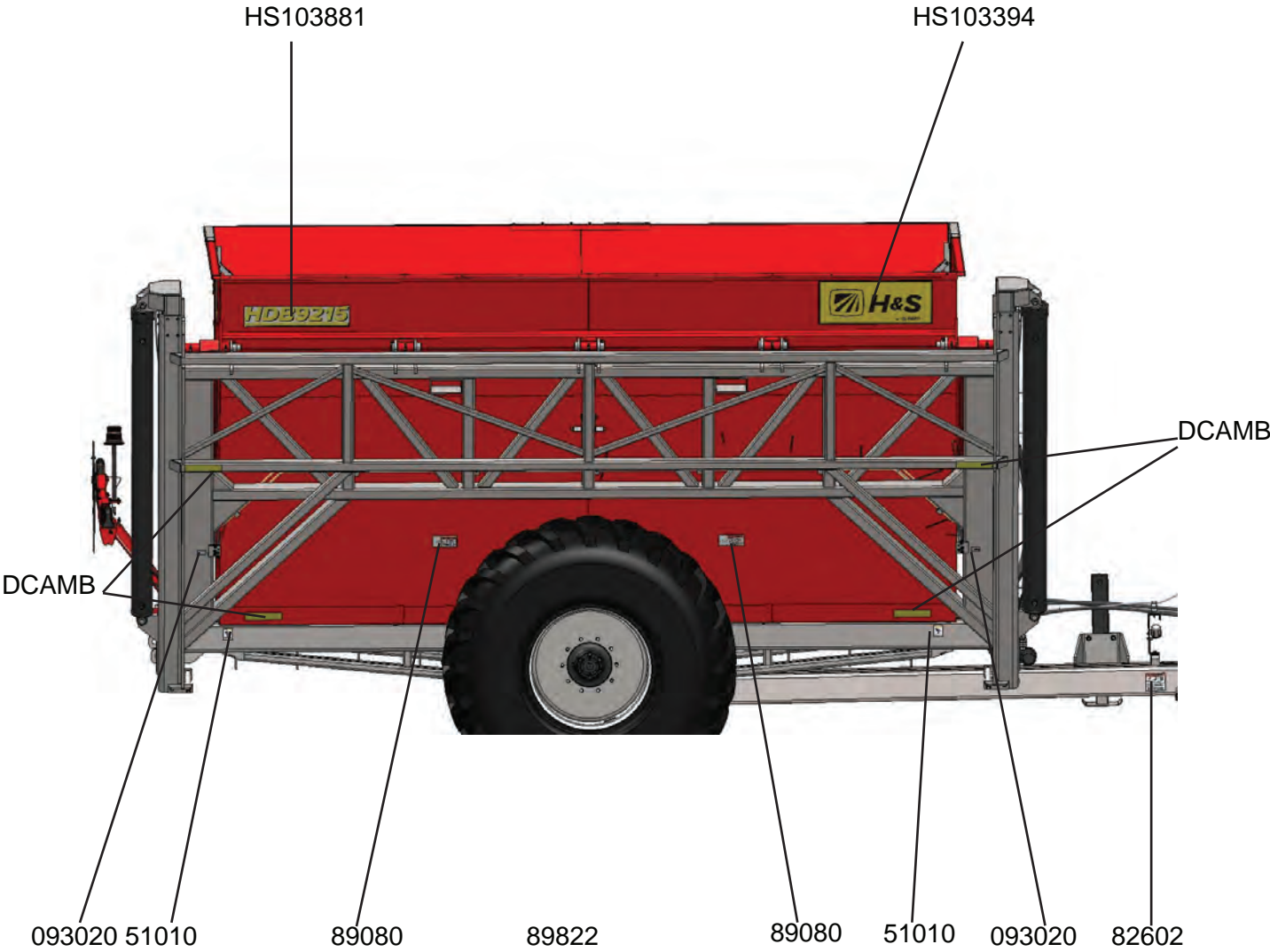

TROUBLESHOOTING



WARNING;
MAKE SURE THAT THE TRACTOR IS SHUT OFF AND THE TRAILER CANNOT MOVE BEFORE SERVICING THE *HI-DUMP*. MAINTENANCE AND REPAIR SERVICE WORK MUST BE PERFORMED BY A QUALIFIED SERVICE PERSON ONLY.

SYMPTOM	POSSIBLE CAUSE	POSSIBLE REMEDY
---------	----------------	-----------------

Box will not raise or lower	<ul style="list-style-type: none"> • No hydraulic power 	<ul style="list-style-type: none"> • Connect hydraulic circuits to tractor properly • Actuate proper hydraulic valve Check quick-couplers to be certain they are completely engaged Replace clogged hydraulic filter in tractor Fill tractor hydraulic oil to proper level
	<ul style="list-style-type: none"> • Lift/Dump cylinder leaking 	<ul style="list-style-type: none"> • Repair or replace cylinder as needed
	<ul style="list-style-type: none"> • Box overloaded 	<ul style="list-style-type: none"> • Remove part of the load
	<ul style="list-style-type: none"> • Insufficient hydraulic pressure 	<ul style="list-style-type: none"> • Use power unit capable of providing 2250 psi. minimum pressure Replace worn hydraulic pump on tractor
	<ul style="list-style-type: none"> • Hydraulic circuit crossed 	<ul style="list-style-type: none"> • Trace hydraulic circuit and connect so front and rear lift cylinders lift in series, & the dump cylinders are plumbed in parallel
Box will not dump properly	<ul style="list-style-type: none"> • Box dumped on side hill 	<ul style="list-style-type: none"> • Dump box on level surface
Box chatters when raising or lowering, or will not raise to full height	<ul style="list-style-type: none"> • Air in hydraulic system 	<ul style="list-style-type: none"> • Actuate lift/dump cylinders to fully extend and retract to purge the system of air
	<ul style="list-style-type: none"> • Oil level low 	<ul style="list-style-type: none"> • Add hydraulic oil to the towing vehicles hydraulic system
	<ul style="list-style-type: none"> • Insufficient reservoir capacity 	<ul style="list-style-type: none"> • Change power unit to provide a minimum reservoir capacity of 20.1 gallons
Box raises or lowers slowly	<ul style="list-style-type: none"> • Not enough hydraulic oil volume 	<ul style="list-style-type: none"> • Use a power unit capable of providing 34.1 GPM minimum Replace worn pump Replace clogged hydraulic filter in tractor Check for leaking fittings
	<ul style="list-style-type: none"> • Lift/Dump cylinder is leaking internally 	<ul style="list-style-type: none"> • Repair or replace Lift/Dump cylinder as needed
	<ul style="list-style-type: none"> • Box overloaded 	<ul style="list-style-type: none"> • Remove part of the load

H&S MFG. CO.

products approved

for the

FEMA SEAL OF QUALITY



Manufactured By:

H&S MANUFACTURING CO., INC.

2608 S. HUME AVE. MARSHFIELD, WI 54449

(715) 387-3414 | hsmfgco.com

