

H&S

PARTS BOOK

S3131 SPREADER



Revision #05
Starting Ser. #811MS31040

Part #72464
HSMFG0318

2608 S. HUME AVE. , MARSHFIELD, WI 54449
(715) 387-3414 FAX (715) 384-5463
www.hsmfgco.com

CONTENTS

Instructions for Ordering Parts - About Improvements	1
Figure 1 - Beater and Pan Assembly	2-3
Figure 2 - Hub, Spindle and Box Parts	4-5
Figure 3 - Front Shield and Drive Assembly	6-9
Figure 4 - Back Shield and Drive Assembly	10-13
Figure 5 - Hydraulic Endgate	14-15
Figure 6 - Apron Chain Assembly	16-17
Figure 7 - Optional Hydraulic Drive Assembly	18-19
Figure 8 - Worm Gearbox Assembly	20-21
Figure 9 - Bevel Gearbox	22-23
Figure 10 - Hydraulic Cylinder	24
Figure 11 - PTO	25
Figure 12 - PTO 1000RPM	26-27
Figure 13 - Optional Second Beater	28-29
Figure 14 - Optional Electric Control for Hydraulic Drive	30-31
Figure 15 - Electric Control for Hydraulic Drive	32
Parts Notes	33-34

INSTRUCTIONS FOR ORDERING PARTS

All service parts should be ordered through your authorized H&S dealer. They will be able to give you faster service if you will provide them with the following

1. Model & Serial number is located in the front center of the Manure Spreader.
2. All reference to left or right apply to the Manure Spreader as viewed from the rear.
3. Parts should not be ordered from illustration only. Please order by complete part number.
4. If your dealer has to order parts - give shipping instructions:

VIA truck - large pieces (please specify local truck lines)

VIA United Parcel Service (include full address)

H&S MFG. CO. INC.	
MARSHFIELD, WIS.	
MOD. NO.	<input type="text"/>
SER. NO.	<input type="text"/>
DESCR.	<input type="text"/>

PLEASE RECORD NUMBERS FOR YOUR UNIT FOR QUICK REFERENCE

ABOUT IMPROVEMENTS

H&S IS CONTINUALLY STRIVING TO IMPROVE IT'S PRODUCTS

We must therefore, reserve the right to make improvements or changes whenever it becomes practical to do so without incurring any obligation to make changes or additions to the equipment previously sold.

FIGURE 1
BEATER & PAN ASSEMBLY

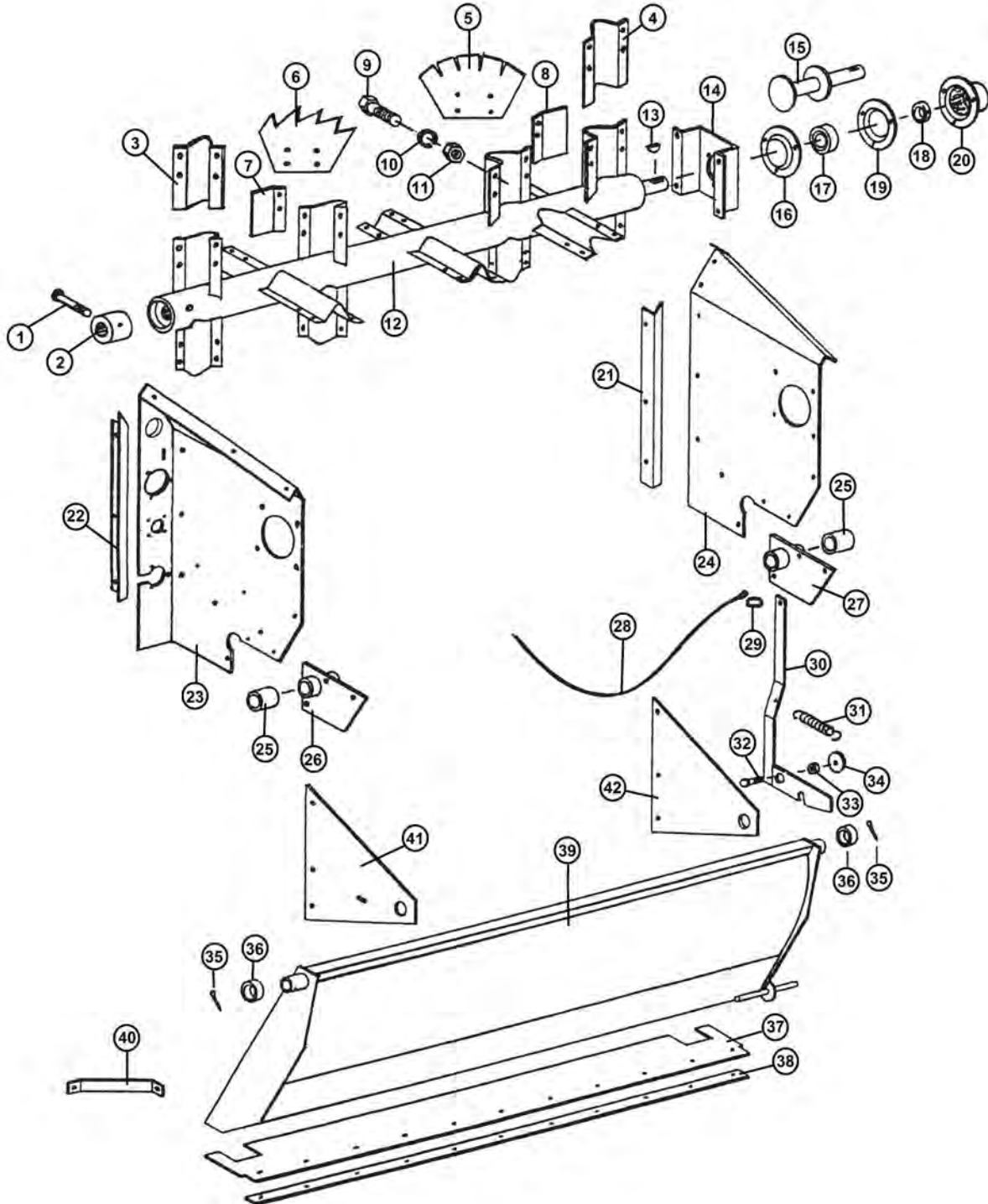

FIGURE 1

BEATER & PAN ASSEMBLY

<u>ITEM</u>	<u>PART #</u>	<u>DESCRIPTION</u>
1	YBHH10130	BOLT HEX 5/16 X 5 G5
2	23N2	SPLINED BEATER INSERT
3	23N3	BEATER BLADE HOLDER LH
4	23N4	BEATER BLADE HOLDER RH
5	23N276	BEATER BLADE - HARDENED
6	23N277	BEATER BLADE - HARDENED
7	23N7	BEATER BLADE WIPER LH
8	23N8	BEATER BLADE WIPER RH
9	YBHH16045	BOLT HEX 1/2 X 1-1/4 G5
10	YWLO16005	WASHER LOCK, 1/2
11	YNL16005	NUT HEX, 1/2 G5
12	23N9	BEATER
13	5B9	WOODRUFF KEY, 3/8 X 1-1/4
14	23N10	BEATER SHAFT SUPPORT
15	23N11	BEATER STUB SHAFT
16	F116	BEARING FLANGE (HEAVY DUTY)
17	12N122	BEARING W/LOCK COLLAR ASSEMBLY
18	12N122	BEARING W/LOCK COLLAR ASSEMBLY
19	F114A	BEARING FLANGE W/ ZERK 450
20	23N12	BEARING FLANGE GUARD
21	23N13	SIDE POLY HOLD DOWN RH
22	23N14	SIDE POLY HOLD DOWN LH
23	23N175	MAIN PANEL LH
24	23N16	MAIN PANEL RH
25	23N17	DRIVE SHAFT BUSHING
26	37N78	DRIVE SHAFT BRACKET W/BUSHING LH
27	23N19	DRIVE SHAFT BRACKET W/BUSHING RH
28	31N1	PAN TRIP ROPE
29	R31	CLIP
30	23N21	PAN TRIP LEVER
31	R27	SPRING
32	YBCR16010	CARR BOLT, 1/2 X 1-1/2 G5
33	23N23	TRIP LEVER SPACER
34	YWFL16005	WASHER FLAT, 1/2 USS
35	YPCT06020	COTTER PIN, 3/16 X 2
36	F112	SPACER
37	23N24	PAN RUBBER FLAP
38	23N25	PAN STRAP
39	23N30	PAN
40	23N267	PAN BRACE
41	23N28	PAN SUPPORT LH
42	23N29	PAN SUPPORT RH

FIGURE 2

HUB, SPINDLE AND BOX PARTS

<u>ITEM</u>	<u>PART #</u>	<u>DESCRIPTION</u>
1	23N31	SIDE STAKE RH
2	23N32	SIDE STAKE LH
3	B8	SEAL
4	75954	INNER BEARING
5	B7	INNER RACE
6	B6	HUB
7	B32	HUB BOLT 16
8	75951	OUTER RACE
9	B5	OUTER BEARING
10	YWFL28005	WASHER FLAT, 7/8 USS
11	YPCT05020	COTTER PIN, 5/32 X 1-3/4
12	YNSL28005	NUT SLOT, 7/8 G2
13	B2	HUB CAP
14	31N2	SPINDLE
*	31N48	SPINDLE FOR 14 X 16.1 WHEEL
15	YPEX16020	EXPANSION PIN, 1/2 X 4
16	31N5	TANDEM BEAM LH
17	31N6	TANDEM BEAM RH
18	YNTL16005	HEX NUT, TOP LOCK, 1/2
19	B60	RING
20	YBHH16150	HEX BOLT, 1/2 X 4-3/4 G5
21	70150	POLY BUSHING
22	23N34	FRONT FLARE
23	F33	ROPE GUIDE
24	YBPU08005	PIPE U BOLT
25	23N35	GATE ANGLE RH
26	23N36	GATE ANGLE LH
27	23N176	FRONT FLARE SUPPORT
28	16V9	GREASE LINE BRACKET
29	23N270A	FRONT GATE PLYWOOD WITH FIBERGLASS
30	23N40	STRAP FOR RUBBER
31	23N41	FRONT GATE RUBBER
32	23N42	SPLASH GUARD SIDE LH
33	23N43	SPLASH GUARD SIDE RH
34	31N24	SIDE FLARE RH
35	31N25	SIDE FLARE LH
36	S47	GREASE LINE FITTING
37	31N32A	SIDE PLYWOOD WITH FIBERGLASS LH
38	31N43	GREASE LINE
39	31N49	POLY FLOOR
40	31N31A	SIDE PLYWOOD WITH FIBERGLASS RH
41	54595	GREASE ZERK, 1/8 NPT
42	75955	HUB W/RACES
43	23N179A	WHEEL, 8.25 X 22.5, 8-BOLT
44	72438	VALVE STEM
45	UR19	TIRE, 295/75R22.5
46	32352	COMPLETE ASSEMBLY
47	70162	POLY BUSHING

FIGURE 3

FRONT SHIELD & DRIVE ASSEMBLY

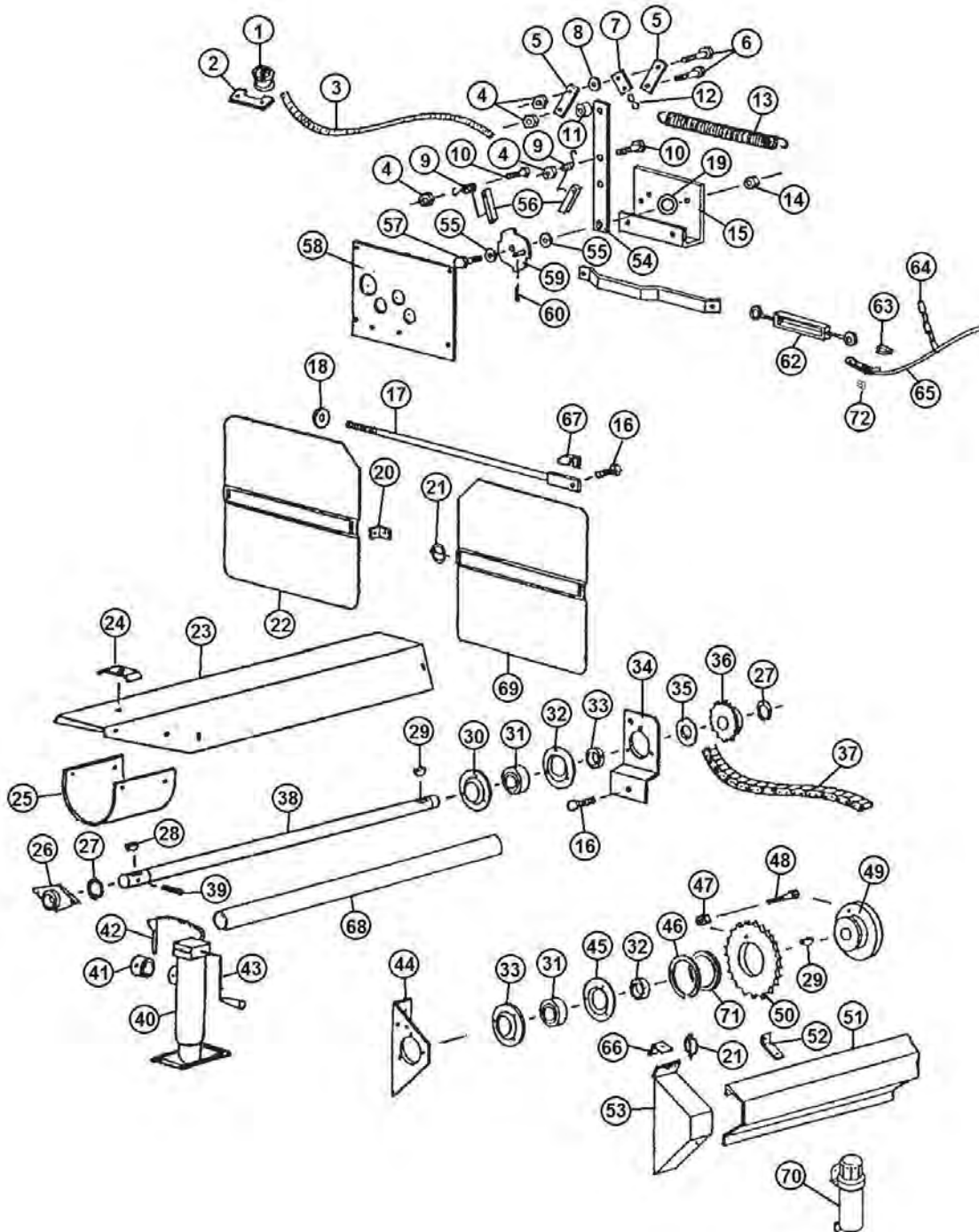

FIGURE 3

FRONT SHIELD & DRIVE ASSEMBLY

<u>ITEM</u>	<u>PART #</u>	<u>DESCRIPTION</u>
1	F33	CABLE GUIDE
2	23N182	BRACKET
3	23N183	ROPE (15)
4	YNTL12005	NUT HEX, 3/8
5	23N184	BRACKET
6	YBHH12035	BOLT HEX 3/8 X 1-1/4 G5
7	23N185	SPRING BRACKET
8	YWFL12005	WASHER FLAT, 3/8 USS
9	23N186	DOG SPRING
10	YBHH12010	BOLT 3/8 X 1 G5
11	D107	SPACER
12	X79	S-HOOK
13	23N187	SPRING
14	YNHX16005	NUT HEX, 1/2
15	23N188	SHIFTER BRACKET
16	YBHH16045	BOLT HEX, 1/2 X 1-1/4 G5
17	23N63	TIGHTENER ROD
18	F129	WASHER
19	31N51	SHIFTER SPACER WASHER
20	F92	SHIELD BRACKET
21	YPLY08010	LYNCH PIN, 1/4 X 1-1/2
22	23N305	FRONT SHIELD
23	23N66	SHIELD
24	23N67	TAILGATE HOSE BRACKET
*	HE42	HYDRAULIC DRIVE BRACKET
25	F54	SHIELD
26	12N29	BEARING
27	F73	SNAP RING
28	5B10	WOODRUFF KEY, 1/4 X 1
29	5B9	WOODRUFF KEY, 3/8 X 1-1/4
30	F114	FLANGE W/STRAIGHT ZERK
31	12N122	BEARING W/LOCK COLLAR 1-1/4
32	12N122	BEARING W/LOCK COLLAR 1-1/4
33	F14	BEARING FLANGE
34	23N68	JACK SHAFT BRACKET
35	23N69	FRONT SHAFT SPACER
36	23N70	SPROCKET (25T)
*	37N72	SPROCKET (16T) (OPTIONAL 1000 RPM)

* MEANS NOT SHOWN

FIGURE 3

FRONT SHIELD & DRIVE ASSEMBLY

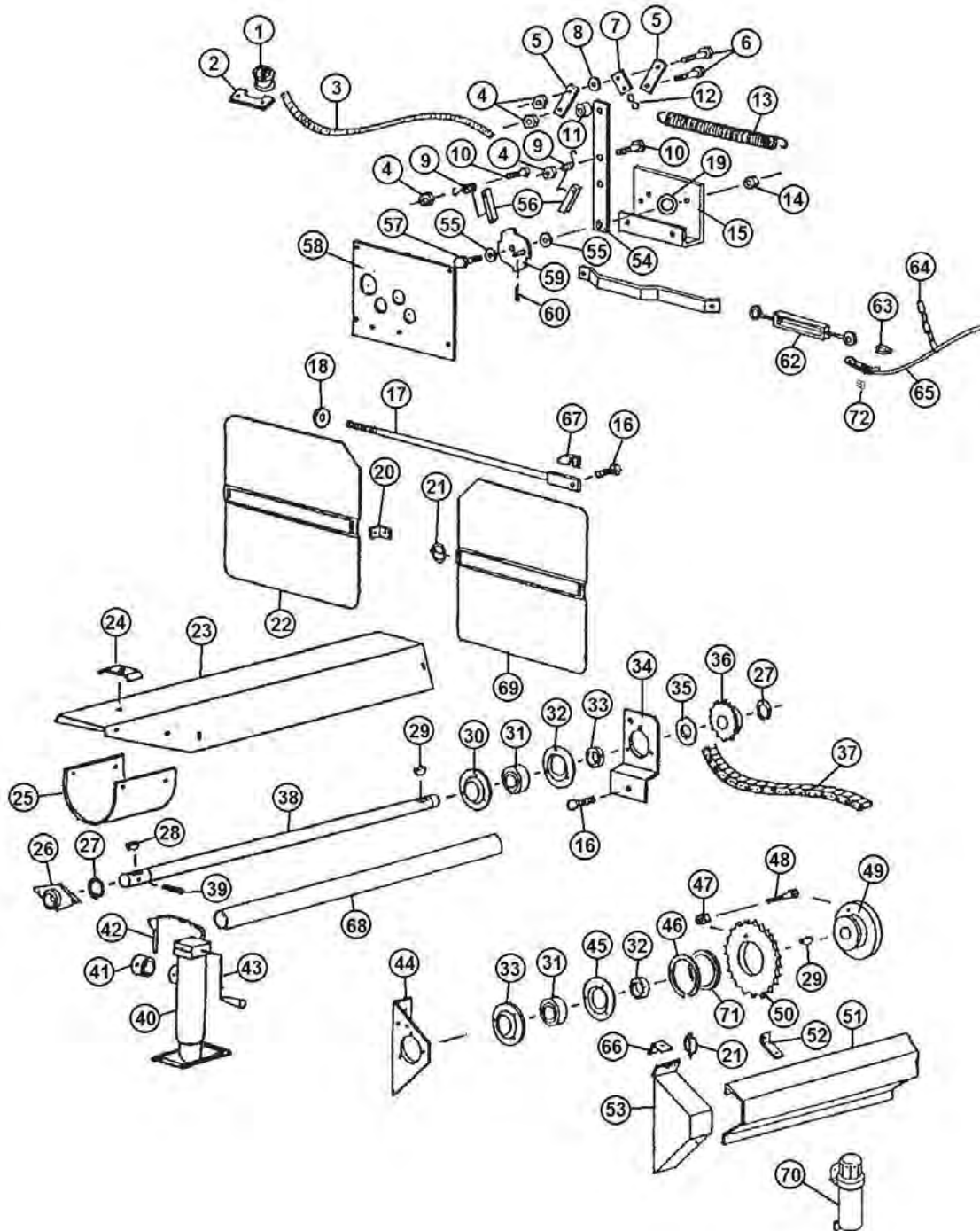

FIGURE 3

FRONT SHIELD & DRIVE ASSEMBLY

<u>ITEM</u>	<u>PART #</u>	<u>DESCRIPTION</u>
37	23N71	ROLLER CHAIN, (#60 122 PITCHES)
38	23N72	FRONT SHAFT
39	YPEX10020	EXPANSION PIN, 5/16 X 2-1/4
40	27N49	JACK
*	12N120	JACK GEAR REPAIR KIT
41	27N51	JACK MOUNT
42	27N50	JACK PIN
43	12N119	HANDLE
*	12N118	REPLACEMENT BEARING
44	23N74	BEARING PLATE
45	F114A	FLANGE
46	23N189	SNAP RING
47	YN TL12005	NUT HEX, TOP LOCK, 3/8
48	YBHH12025	BOLT HEX, 3/8 X 1-1/2 G5
49	45N71	SHEAR HUB
50	C1MS01	SHEAR SPROCKET
51	31N17	SIDE SHIELD
52	23N79	BRACKET
53	23N80	SHIELD
54	23N192	FRONT SHIFTER ARM
55	YWFL16005	WASHER FLAT, 1/2 USS
56	23N193	DOG
57	YBHH16055	BOLT HEX, 1/2 X 1-3/4 G5
58	23N195	SHIFTER PANEL
59	23N196	SPEED SELECTOR
60	YPCT04005	COTTER PIN, 1/8 X 1
61	23N197	SHIFTER ARM
62	F84	TURNBUCKLE
63	ES14	CABLE LOOP
64	23N198	CABLE CHAIN
65	31N27	CABLE
66	23N242	SHIELD BRACKET
67	23N278	SPACER
68	37N74	FRONT SHAFT GUARD
69	23N306	FRONT SHIELD LH
70	S522	MANUAL HOLDER
71	C112G01	SHEAR HUB SPACER
72	ES15	CABLE CLAMP, 1/8

*** MEANS NOT SHOWN**

FIGURE 4
BACK SHIELDS & DRIVE ASSEMBLY

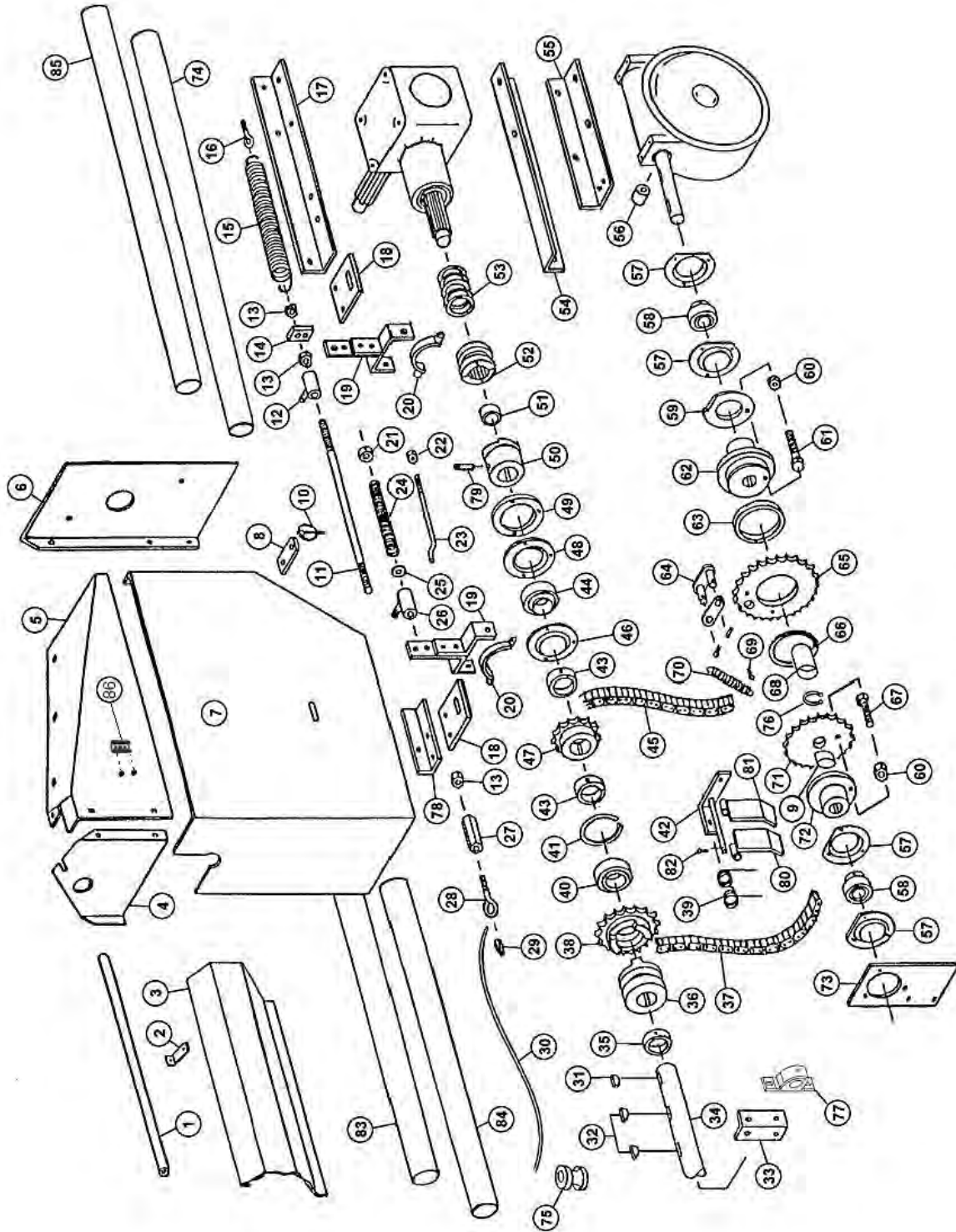

FIGURE 4

BACK SHIELDS & DRIVE ASSEMBLY

<u>ITEM</u>	<u>PART #</u>	<u>DESCRIPTION</u>
1	23N200	CABLE GUARD
2	23N79	SIDE SHIELD BRACKET
3	31N28	SIDE SHIELD
4	23N201	SHIELD
5	23N202	BACK SHIELD TOP
6	23N203	BACK SHIELD
7	23N204	COVER
8	23N96	SHIELD BRACKET
9	56027	BUSHING
10	S122	LYNCH PIN W/CABLE
11	23N205	CLUTCH ROD
12	23N206	SHIFTING ROD BRACKET
13	YNHX12005	NUT HEX, 3/8
14	23N207	SPRING BRACKET
15	K103	SPRING
16	YBTE08005	TURNED EYE BOLT, 1/4 X 1 FULL THREAD
17	23N85	TOP ANGLE
18	23N86	SHIFTER BRACKET
19	D57	SHIFTER LEVER
20	23N208	YOKE W/ ZERK
21	23N209	COLLAR
22	YNTL08005	NUT HEX, TOP LOCK, 1/4
23	23N210	SHIFTING ROD
24	23N211	SPRING BRACKET
25	YWFL12005	WASHER FLAT, 3/8 USS
26	23N206	ROD BRACKET
27	23N212	COUPLING NUT
28	YBTE12005	TURNED EYE BOLT, 3/8 X 1
29	ES14	CABLE LOOP
30	31N27	CABLE
31	5B9	WOODRUFF KEY, 3/8 X 1-1/4
32	5B10	WOODRUFF KEY, 1/4 X 1
33	23N97	SIDE BEARING BRACKET
34	31N29	SIDE SHAFT
35	F6	COLLAR
36	23N215	CLUTCH THROW-OUT
37	23N93	CHAIN (#50 60 PITCHES)
38	23N216	CLUTCH SPROCKET
*	61138	INCLUDES (SPROCKET,BEARING,SNAP RING)
39	31N33	SPRING TIGHTENER
40	BFR525	BEARING
41	3G19	SNAP RING
42	31N36	TIGHTENER BRACKET
43	12N122	BEARING W/LOCK COLLAR 1-1/4
44	12N122	BEARING W/LOCK COLLAR 1-1/4
45	23N93	CHAIN (#50 60 PITCHES)
46	F114A	FLANGE
47	10R11	SPROCKET (13T)

* MEANS NOT SHOWN

FIGURE 4

BACK SHIELDS & DRIVE ASSEMBLY

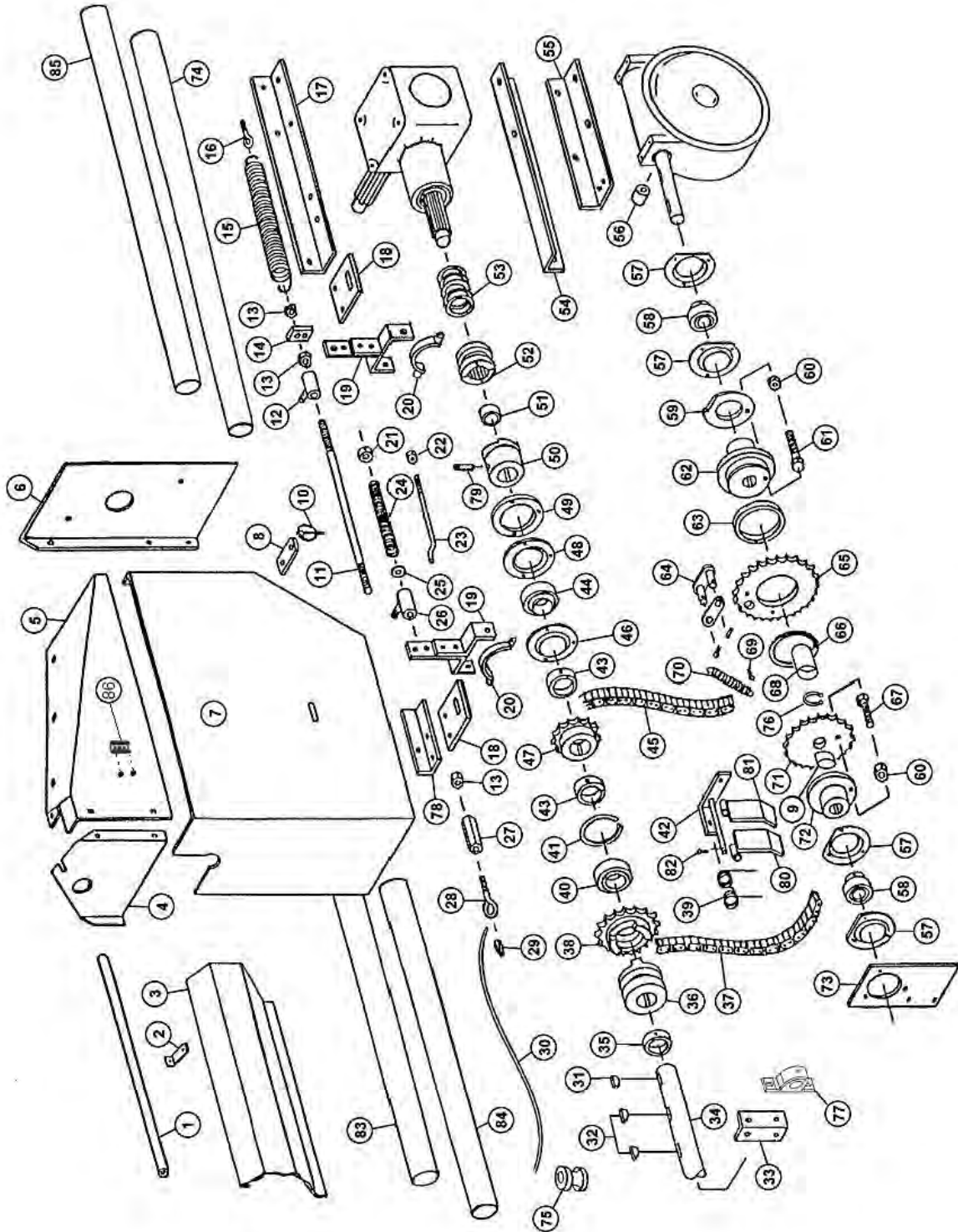

FIGURE 4

BACK SHIELDS & DRIVE ASSEMBLY

<u>ITEM</u>	<u>PART #</u>	<u>DESCRIPTION</u>
48	F14	FLANGE
49	23N174	FLANGE SPACER
50	23N241	CLUTCH
51	D68	BRONZE BUSHING
52	23N90	CLUTCH
53	23N89	SPRING
54	23N88	BOTTOM ANGLE
55	23N95	WORM BOX HOLDER
56	23N94	SPACER
57	X85	FLANGE
58	23N221	BEARING W/ SETSCREWS
59	23N222	SHEAR PLATE
60	YNTL08005	NUT HEX, TOP LOCK, 1/4
61	YBHH08035	BOLT HEX, 1/4 X 1-1/4 GR. 5
62	23N224	SHEAR HUB
63	23N225	BUSHING, BRONZE
64	60531	CONNECTOR LINK W/ PINS
65	74381	SPROCKET, (50 A 30)
*	23N226	SPROCKET W/BUSHING (50 A 30)
66	23N227	SNAP RING
67	YBHH08035	BOLT HEX, 1/4 X 1-1/4 G5
68	56029	SPACER
69	YPCT04005	COTTER PIN, 1/8 X 1
70	23N229	DOG SPRING
71	56026	SPROCKET (25T)
72	56025	SHEAR HUB
73	23N230	BEARING PANEL
74	31N46	#3 SIDE SHAFT GUARD CABLE
75	F33	GUIDE
76	56024	EXTERNAL SNAP RING 1-1/2
77	12N36	PILLOW BLOCK BEARING 1-1/4
78	23N239	SHIFTER SUPPORT
79	YSFD12005	SET SCREW, SOCKET, FULL DOG PT, 3/8X 3/4
80	31N34	TIGHTENER BAR LH
81	31N35	TIGHTENER BAR RH
82	YPCT04005	COTTER PIN, 1/8 X 1
*	X60	OFFSET LINK (#50)
*	X61	CONNTOR (#50)
*	31N38	CHAIN TIGHTENER ASSEMBLY
83	31N44	#2 SIDE SHAFT GUARD
84	31N45	#1 SIDE SHAFT GUARD
85	60643	#4 SIDE SHAFT GUARD
*	56036	SPROCKET BUSHING
86	F97	SMV BRACKET

*** MEANS NOT SHOWN**

FIGURE 5

HYDRAULIC ENDGATE ASSEMBLY

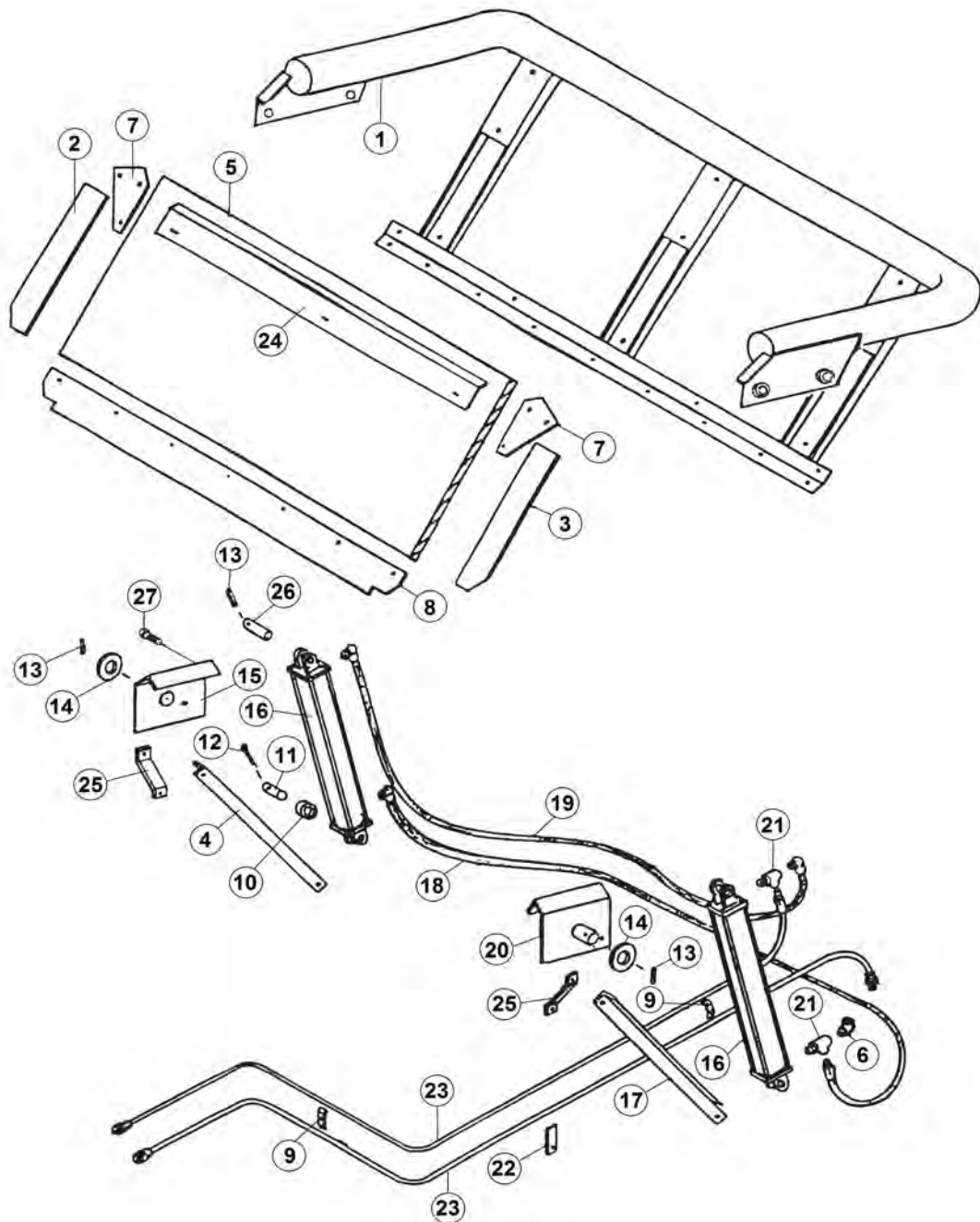

FIGURE 5

HYDRAULIC ENDGATE ASSEMBLY

<u>ITEM</u>	<u>PART #</u>	<u>DESCRIPTION</u>
1	23N298	TAILGATE FRAME
2	23N99	SIDE RUBBER RH
3	23N100	SIDE RUBBER LH
4	23N233	TAILGATE BRACKET
5	31N37A	TAILGATE PLYWOOD W/FIBERGLASS
6	23N234	FITTING 90, 3/8NPT X 1/4NPT
7	23N104	TAILGATE CORNER
8	23N105	BOTTOM RUBBER
9	23N67	HOSE BRACKET
10	K132	SPACER
11	23N107	CYLINDER PIN
12	YPCT07005	COTTER PIN, 7/32 X 2
13	YPEX10015	EXPANSION PIN, 5/16 X 1-3/4
14	23N109	SPACER
15	23N299	TAILGATE MOUNT RH
16	56015	HYD CYLINDER 2 X 16
17	23N231	TAILGATE BRACE LH
18	23N113	HYD HOSE, 6 X 96
19	23N114	HYD HOSE, 6 X 138
20	23N300	TAILGATE MOUNT LH
21	23N116	FITT TEE, 3/8NPT X 3/8NPT X 3/8NPT
22	23N117	HOSE HOLDER
23	77331	HYD HOSE, 6 X 238
24	23N163	TAILGATE POLY HOLD DOWN
25	23N232	TAILGATE BRACKET
26	23N301	CYLINDER PIN
27	YBCR16021	BOLT CARRIAGE, 1/2 X 1-3-4 G5

*** MEANS NOT SHOWN**

FIGURE 6
APRON CHAIN ASSEMBLY

FIGURE 6

APRON CHAIN ASSEMBLY

<u>ITEM</u>	<u>PART #</u>	<u>DESCRIPTION</u>
1	37N82	DRIVE SHAFT SHIELD
2	23N303	SQUARE KEY, 3/8 X 1-3/4
3	27N19	DRIVE SHAFT
4	S138	ROUND KEY, 3/8 X 2-3/8
5	23N121	SPACER
6	23N122	DRIVE SPROCKET (6T)
7	31N21	APRON CHAIN, 26 SLATS 262 LINKS
8	23N124	SLAT W/ ATTACHMENT LINKS
9	S55	T-ROD STANDARD LINK
10	S56	T-ROD CONNECTOR LINK
11	31N22	APRON CHAIN SIDE SPACERS
12	A30	CHAIN SLIDE PLATE LH
13	23N126	CHAIN SLIDE SPACER
14	23N127	T-ROD SLIDE LH
15	23N128	T-ROD SLIDE RH
16	YBCR16045	BOLT CARRIAGE, 1/2 X 4 G5
17	YBHH16145	BOLT HEX, 1/2 X 4-1/2 G5
18	A29	CHAIN SLIDE PLATE RH
19	23N266	PIPE SPACER
20	75563	SPACER BLOCK W/HOLE LH
21	75562	SPACER BLOCK W/O HOLE RH

FIGURE 7
OPTIONAL HYDRAULIC DRIVE ASSEMBLY

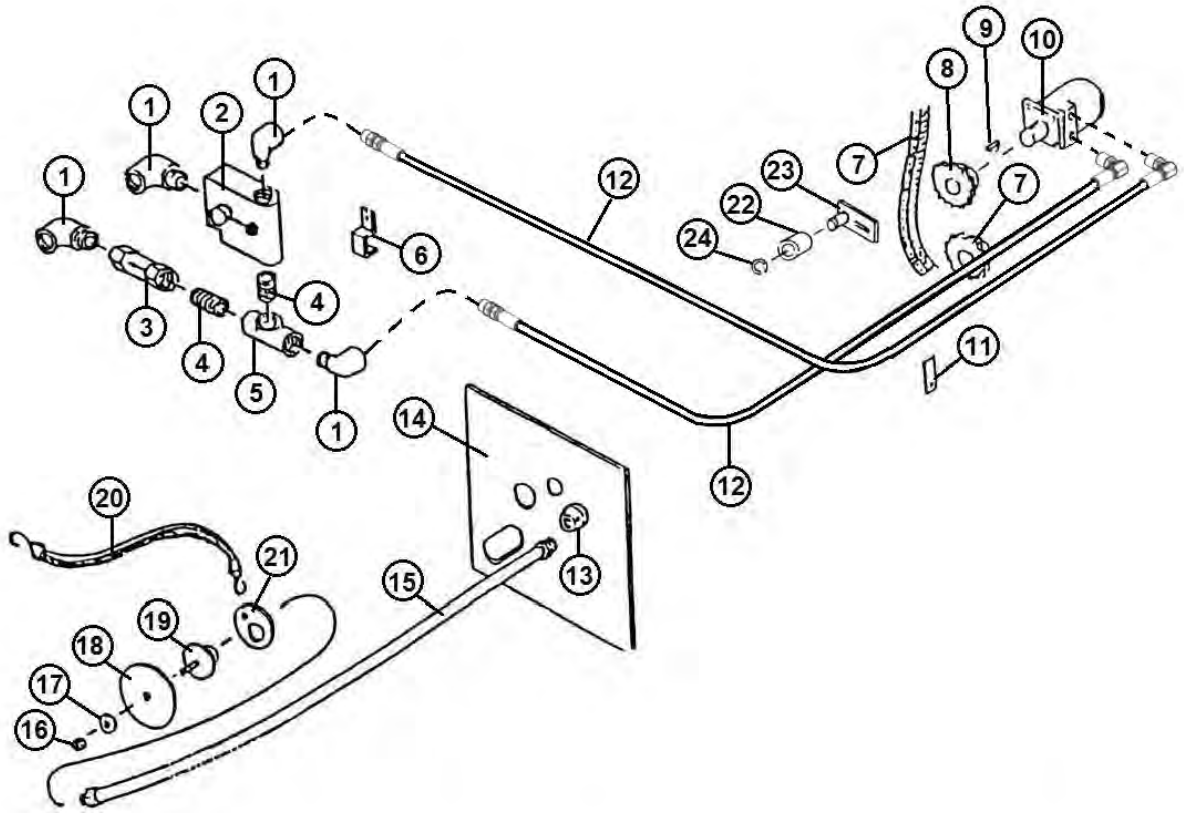

FIGURE 7

OPTIONAL HYDRAULIC DRIVE ASSEMBLY

<u>ITEM</u>	<u>PART #</u>	<u>DESCRIPTION</u>
1	HE58	FIT 90, 1/2NPT X 1/2NPT
2	DF15A	SPEED CONTROL
3	DF18	CHECK VALVE
4	DF7	FIT STRAIGHT, 1/2NPT X 1/2NPT
5	DF8	FIT TEE, 1/2NPT X 1/2NPT X 1/2NPT
6	HE14	PIPE BRACKET
7	23N131	ROLLAR CHAIN, (#50, 40 PITCHES)
8	11S19	SINGLE SPROCKET (20T)
9	5B10	WOODRUFF KEY, 1/4 X 1
10	DF1	HYD MOTOR
11	23N117	HOSE HOLDER
12	77330	HYD HOSE, 6, 224IN
13	DF21	REDUCER
14	23N133	CONTROL PANEL
15	DF9	HYD HOSE, 8, 72IN
16	YNTL12005	NUT HEX, 3/8
17	DF12	SPACER
18	DF11	CONTROL HANDLE
19	DF10	HANDLE BRACKET
20	DF14	STRAP
21	DF22	RING FOR STRAP
22	23N238	CHAIN TIGHTENER ROLLER
23	L10R35	CHAIN TIGHTENER
24	10R32	SNAP RING, EXTERNAL

FIGURE 8
WORM GEARBOX ASSEMBLY

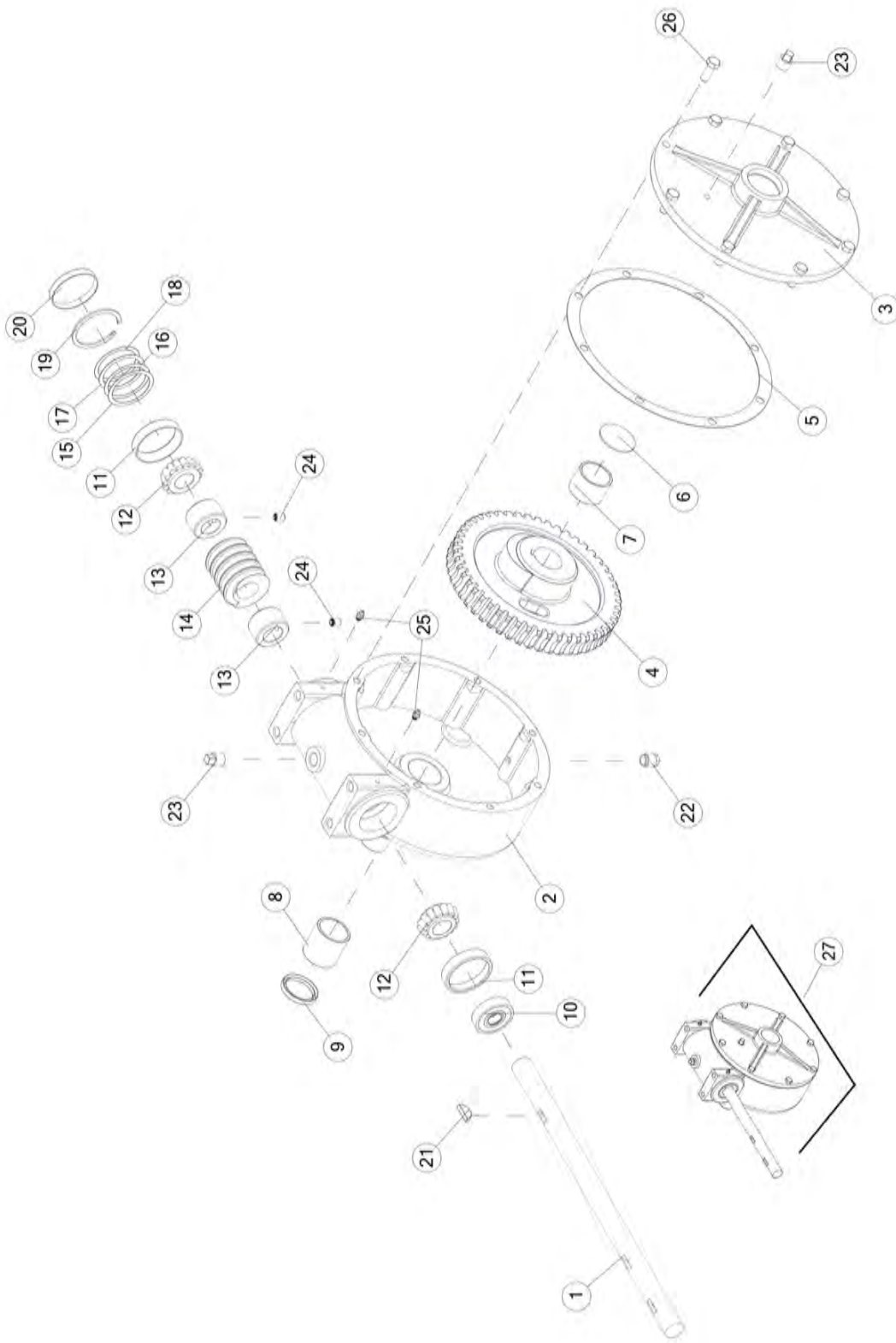

FIGURE 8

WORM GEARBOX ASSEMBLY

<u>ITEM</u>	<u>PART #</u>	<u>DESCRIPTION</u>
1	23N236	WORM GEAR SHAFT
2	G114	GEAR BOX HOUSING
3	G116	WORM GEAR BOX COVER
4	G77	WORM GEAR ASSEMBLY
5	G88	GASKET
6	G117	CAP
7	X75	BUSHING
8	X8	BUSHING
9	17G133	SEAL
10	G123	SEAL
11	12N19	INNER RACE
12	3G7	TAPER BEARING
13	X9	SPACER
14	G76	WORM
15	G92	SHIM, STAINLESS .010
16	59249	SHIM STOCK .005
17	59250	SHIM STOCK .020
18	58748	SHIM STOCK .007
19	3G19	SNAP RING, INTERNAL
20	G90	CAP
21	5B10	WOODRUFF KEY, 1/4 X 1
22	3G20	VENT PLUG
23	G65	PLUG PIPE 3/8 NPT
24	YSKP12010	SCREW SOCKET, 3/8 X 1/2
25	G89	STRAIGHT ZERK, 1/4
26	YBHH12010	BOLT HEX, 3/8 X 1 G5
27	G122	WORM GEAR BOX

FIGURE 9

BEVEL GEARBOX

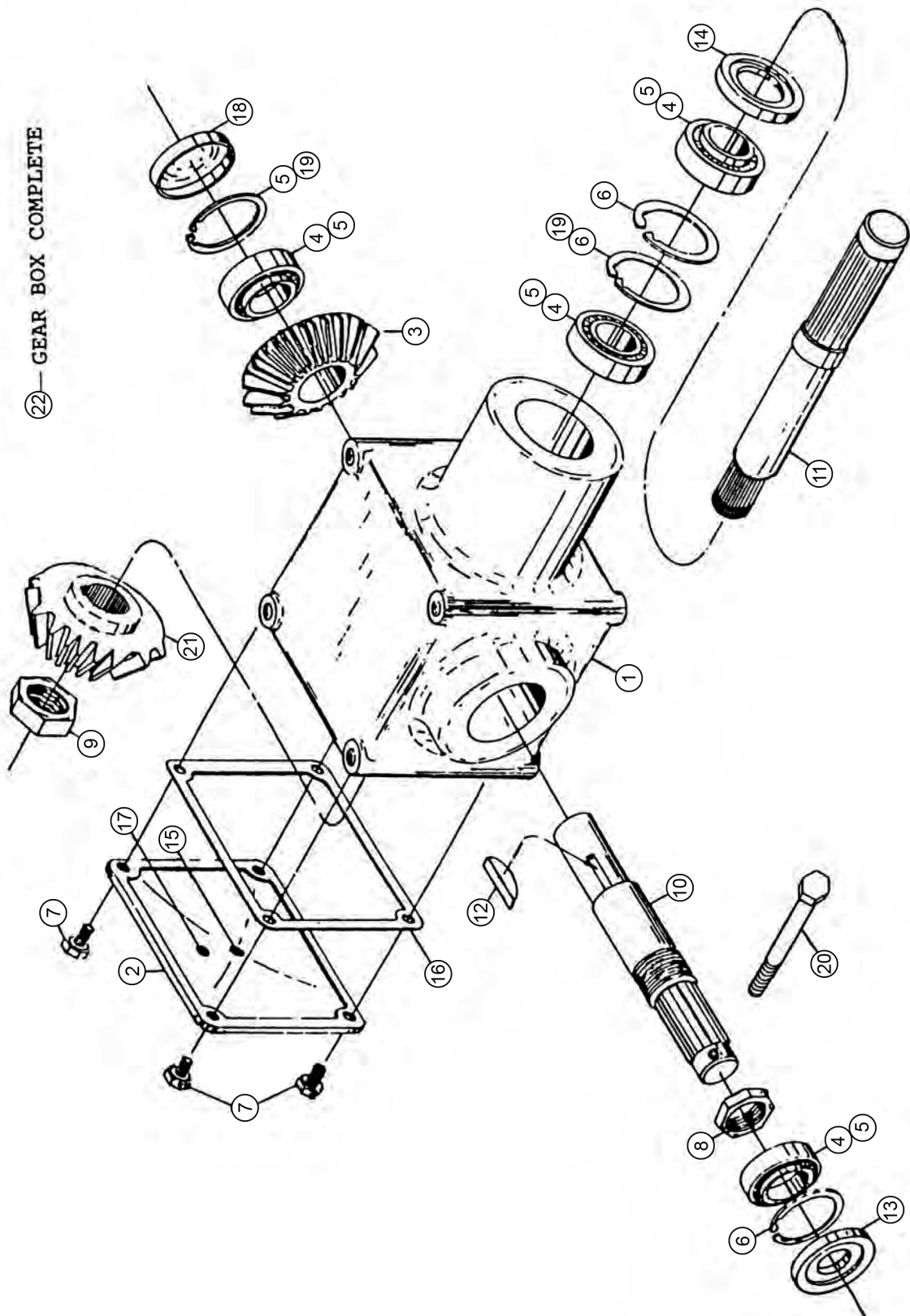

FIGURE 9

BEVEL GEARBOX

<u>ITEM</u>	<u>PART #</u>	<u>DESCRIPTION</u>
1	G50	HOUSING
2	G51	COVER
3	23N136	BEVEL GEARBOX (24T)
4	G53	BEARING
5	G54	RACE
6	G55	SNAP RING
7	YBHH10132	CAPSCREW, 5/16 X 5/8
8	G57	STAKE NUT 1-1/2
9	31N39	STAKE NUT 1-1/8
10	23N137	OUTPUT SHAFT
11	31N40	INPUT SHAFT, DOUBLE SPLINED
12	G61	WOODRUFF KEY
13	G63	OUTPUT SEAL
14	G64	INPUT SEAL
15	G65	PLUG, 1/8 NPT
16	G66	GASKET
17	G67	PLUG, 1/8 NPT
18	G68	CAP
19	G69	SHIM
20	YBHH10130	BOLT HEX, 5/16 X 5 G5
21	31N41	BEVEL GEAR (16T)
22	31N42	COMPLETE GEARBOX
*	18VB25	RACE

FIGURE 10

HYDRAULIC CYLINDER

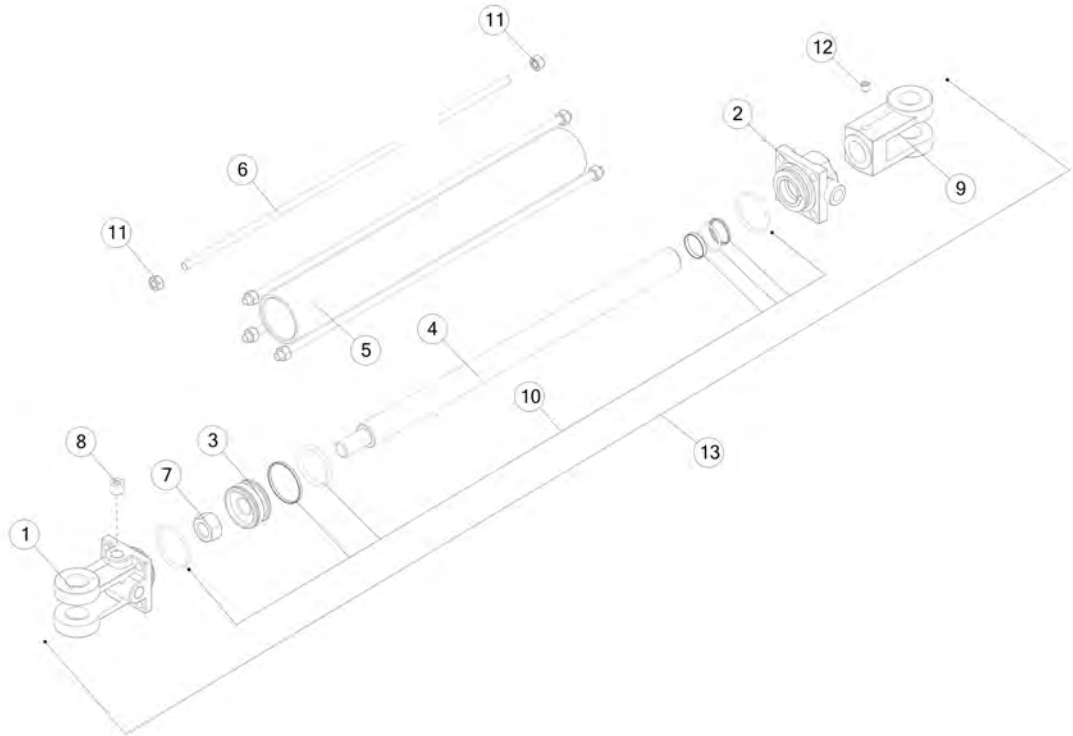

<u>ITEM</u>	<u>PART #</u>	<u>DESCRIPTION</u>
1	23N142A	CLEVIS CAP FOR 2 IN CYLINDER
2	56174	ROD CAP
3	56180	PISTON FOR 2 IN CYLINDER
4	23N145A	ROD
5	23N146	CYLINDER TUBE
6	23N147	SHAFT, RND, 0.33 X 20.19
7	23N148	PISTON NUT
8	23N149	PLUG
9	23N150A	ROD CLEVIS
10	56187	SEAL KIT FOR 2 IN CYLINDER
11	YNHX12006	NUT HEX, 3/8 G2
12	YSSO12015	SET SCREW, SOCKET, 3/8 X 3/8
13	56015	HYDRAULIC CYLINDER (2 X 16)

FIGURE 11

PTO ASSEMBLY

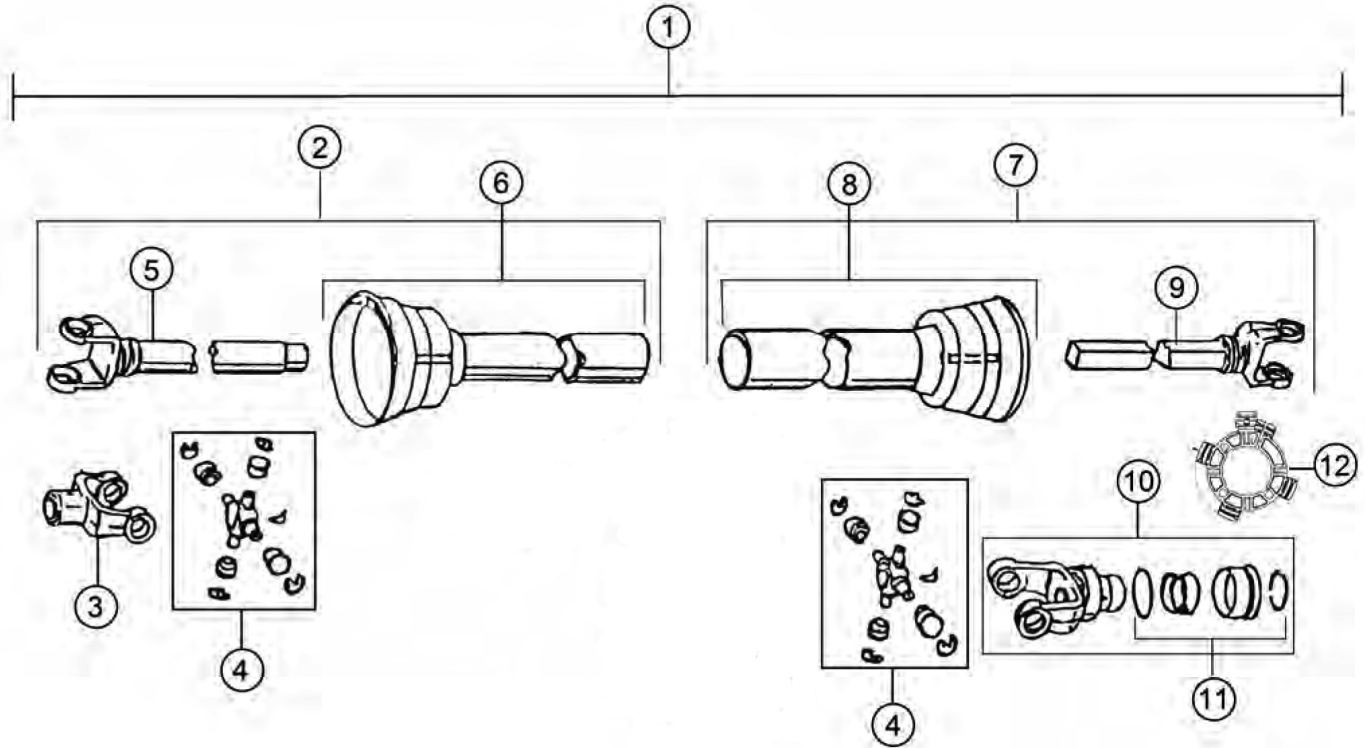

<u>ITEM</u>	<u>540 RPM</u>	<u>DESCRIPTION</u>
1	23N152	COMPLETE PTO
2	23N153	MACHINE HALF PTO W/SHIELD
3	G1R35	YOKE 1-1/4
4	14NW	14R CROSS & BEARING KIT
5	23N155	YOKE AND TUBE
6	23N156	INNER GUARD
7	23N157	TRACTOR HALF PTO W/SHIELD
8	23N158	OUTER GUARD
9	23N159	YOKE AND SHAFT
10	23N162	PTO LOCK YOKE ASSEMBLY (540)
11	S225	SPRING-LOK REPAIR KIT
12	16SV181	NYLON REPAIR
*	S402	ADMA SAFETY MANUAL

* MEANS NOT SHOWN

FIGURE 12
PTO ASSEMBLY (1000RPM)

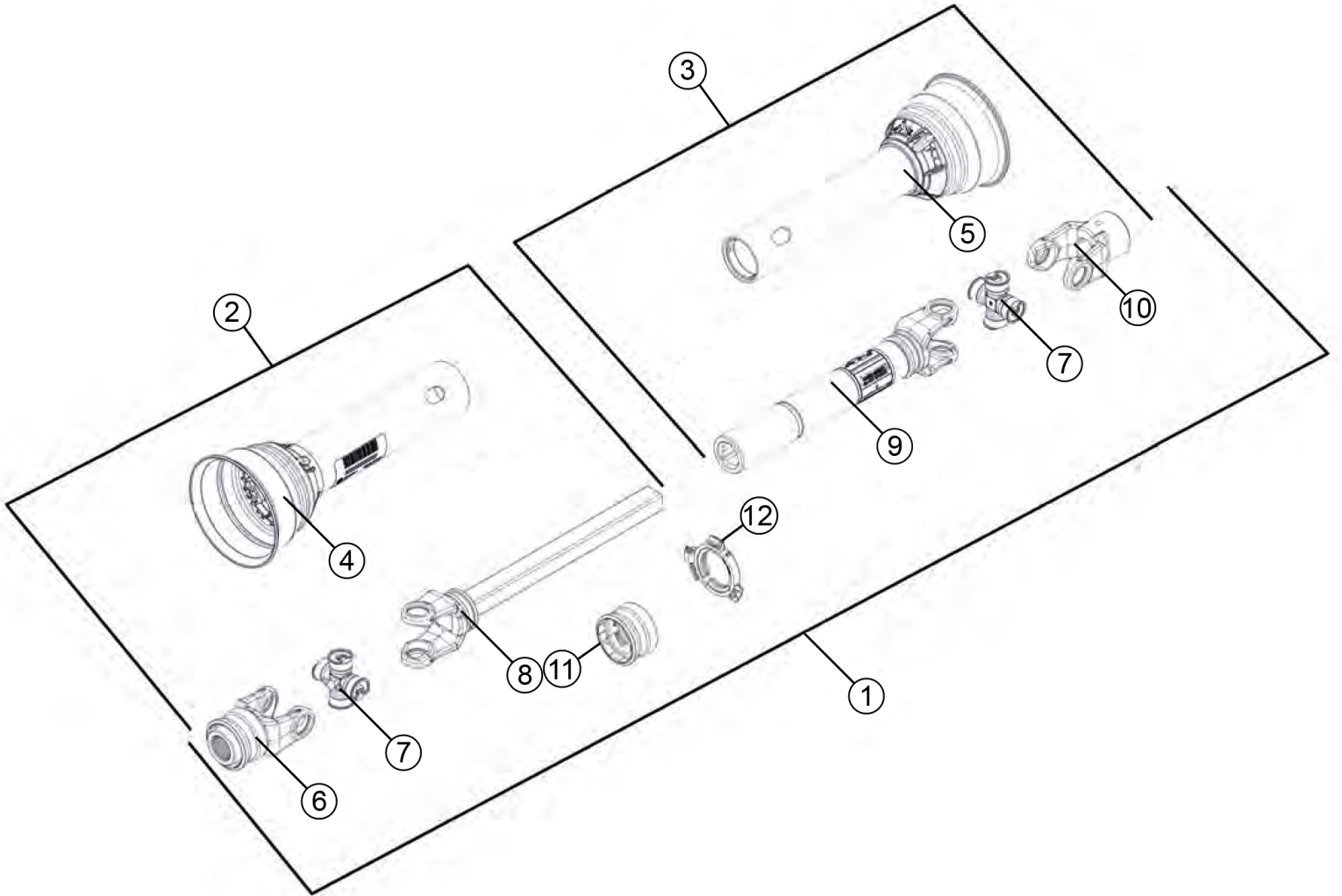

FIGURE 12
PTO ASSEMBLY (1000RPM)

<u>ITEM</u>	<u>PART #</u>	<u>DESCRIPTION</u>
1	23N313	COMPLETE PTO
2	23N314	TRACTOR HALF W/SHIELD
3	23N153	MACHINE HALF PTO W/SHIELD
4	55864	OUTER GUARD
5	23N156	INNER GUARD
6	37N73	1000 RPM YOKE
7	14NW	14R CROSS & BEARING KIT
8	23N159	YOKE AND SHAFT
9	23N155	YOKE AND TUBE
10	G1R35	YOKE 1-1/4
11	S225	SPRING-LOK REPAIR KIT
12	55861	GUARD REPAIR KIT
*	S402	ADMA SAFETY MANUAL

*** MEANS NOT SHOWN**

FIGURE 13
OPTIONAL 2ND BEATER

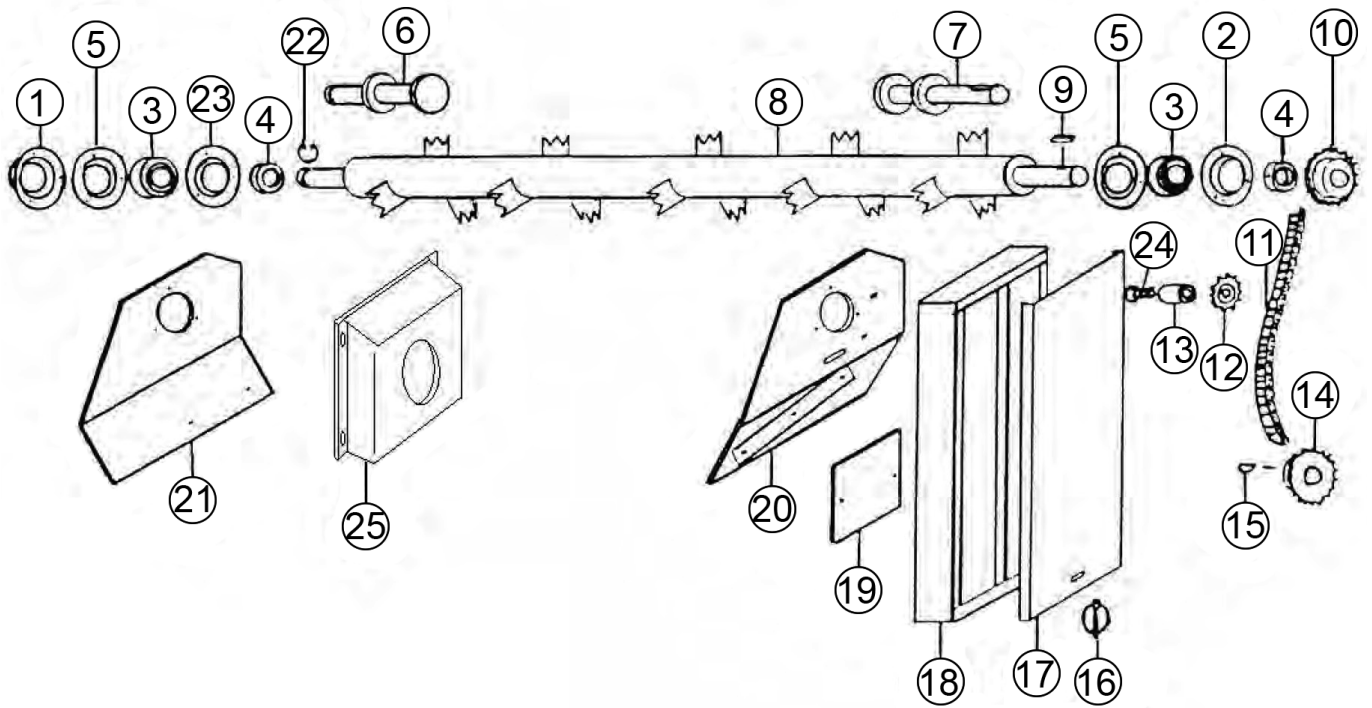

FIGURE 13

OPTIONAL 2ND BEATER

<u>ITEM</u>	<u>PART #</u>	<u>DESCRIPTION</u>
1	77318	BEARING FLANGE
2	F114A	BEARING FLANGE W/45 DEG ZERK
3	12N122	BEARING W/LOCK COLLAR 1-1/4
4	12N122	BEARING W/LOCK COLLAR 1-1/4
5	F14	BEARING FLANGE W/ZERK
6	23N164	STUB SHAFT LH
7	23N165	STUB SHAFT RH
8	23N166	SECOND BEATER
9	G23	SQUARE KEY, 5/16 X 1-1/4
10	D18	SPROCKET (16T)
11	23N167	ROLLER CHAIN, (#50, 81 PITCHES)
12	12N42	IDLER SPROCKET (15T)
13	23N168	SPACER
14	F13	SPROCKET (20T)
15	5B9	WOODRUFF KEY, 3/8 X 1-1/4
16	S122	LYNCH PIN W/CABLE
17	23N169	COVER
18	23N170	SHIELD
19	23N171	SHIELD
20	23N172	BEATER PANEL RH
21	23N173	BEATER PANEL LH
22	F73	SNAP RING
23	F114A	BEARING FLANGE W/45 DEG ZERK
24	YBCR1604	BOLT CARRIAGE, 1/2 X 3-1/2 G5
25	57216	BEARING PROTECTOR

FIGURE 14
OPTIONAL ELECTRIC CONTROL FOR HYDRAULIC DRIVE

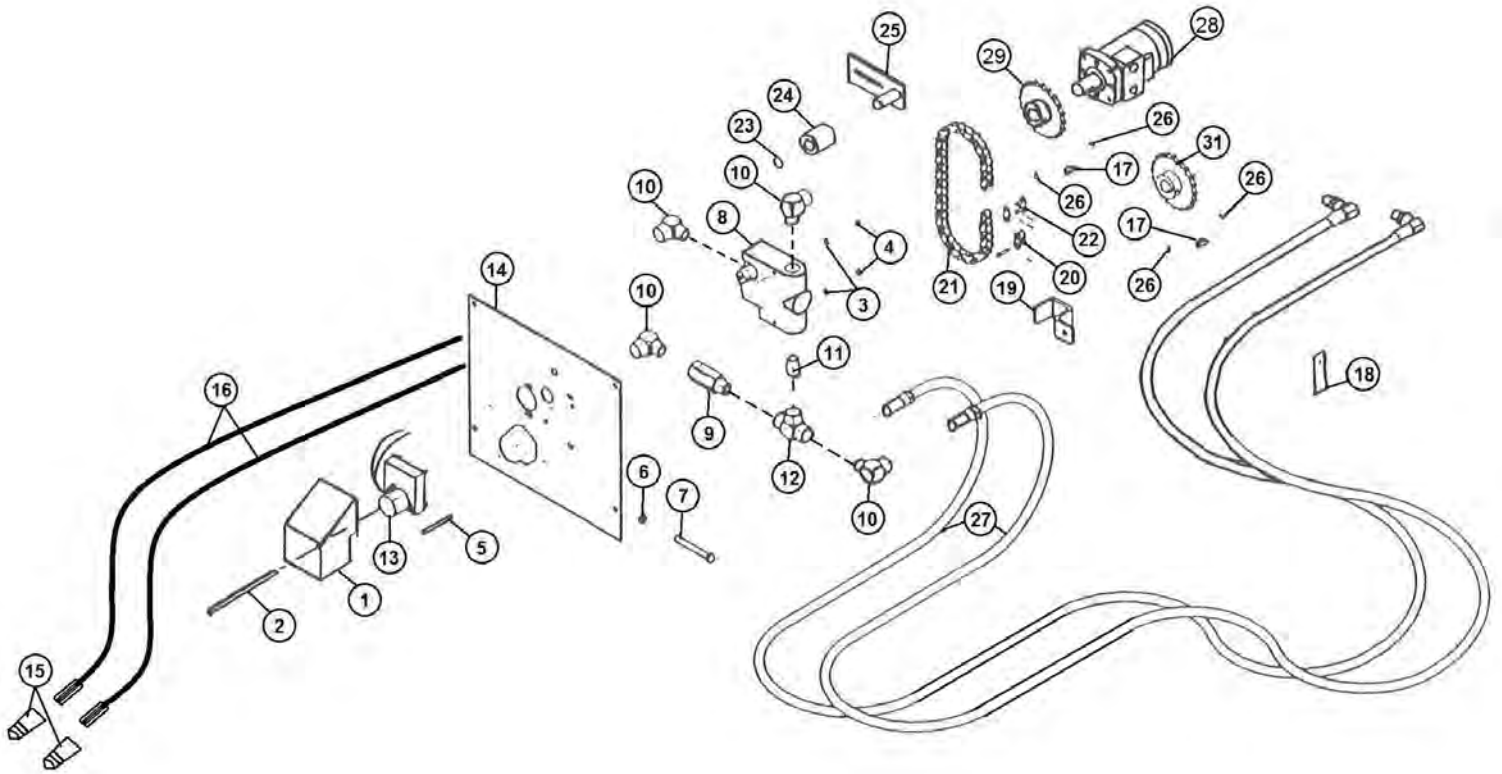

FIGURE 14

OPTIONAL ELECTRIC CONTROL FOR HYDRAULIC DRIVE

<u>ITEM</u>	<u>PART #</u>	<u>DESCRIPTION</u>
1.	43H1	MOTOR SHIELD HOLDER
2.	43H3	SHIELD BOLT
3.	YWLO08005	WASHER LOCK, 1/4
4.	YNTL08005	NUT HEX, 1/4 G2
5.	YBCR08025	BOLT CARRIAGE, 1/4 X 2-1/2 G5
6.	YNTL12005	NUT HEX, 3/8
7.	43H5	FLOW INDICATOR BOLT 3/8 X 3 G2
8.	DF15A	FLOW CONTROL
9.	DF18	CHECK VALVE
10.	HE58	FIT, 90, 1/2NPT X 1/2NPT
11.	DF4	FIT, STRAIGHT, 1/2NPT X 1/2NPT
12.	DF8	FIT, TEE, 1/2NPT X 1/2NPT X 1/2NPT
13.	16SV246	GEAR MOTOR
14.	23N133	CONTROL PANEL
15.	DWM205	MALE QUICK COUPLER
16.	23N309	HYD HOSE, 8 X 96
17.	5B10	WOODRUFF KEY, 1/4 X 1
18.	23N117	HOSE HOLDER
19.	HE14	PIPE BRACKET
20.	X60	OFFSET LINK (#50)
21.	23N131	ROLLER CHAIN (#50, 40 PITCHES)
22.	X61	CONNECTOR LINK (#50)
23.	10R32	EXTERNAL SNAP RING
24.	23N238	CHAIN TIGHTENER ROLLER
25.	L10R35	TIGHTENER BRAKET
26.	YSKP10010	SCREW, SOCKET HEAD 5/16 X 3/8
27.	77330	HYD HOSE, 6, 224IN
28.	DF1	HYDRAULIC MOTOR
29.	11S19	DRIVE SPROCKET (20T)

FIGURE 15

ELECTRIC CONTROL

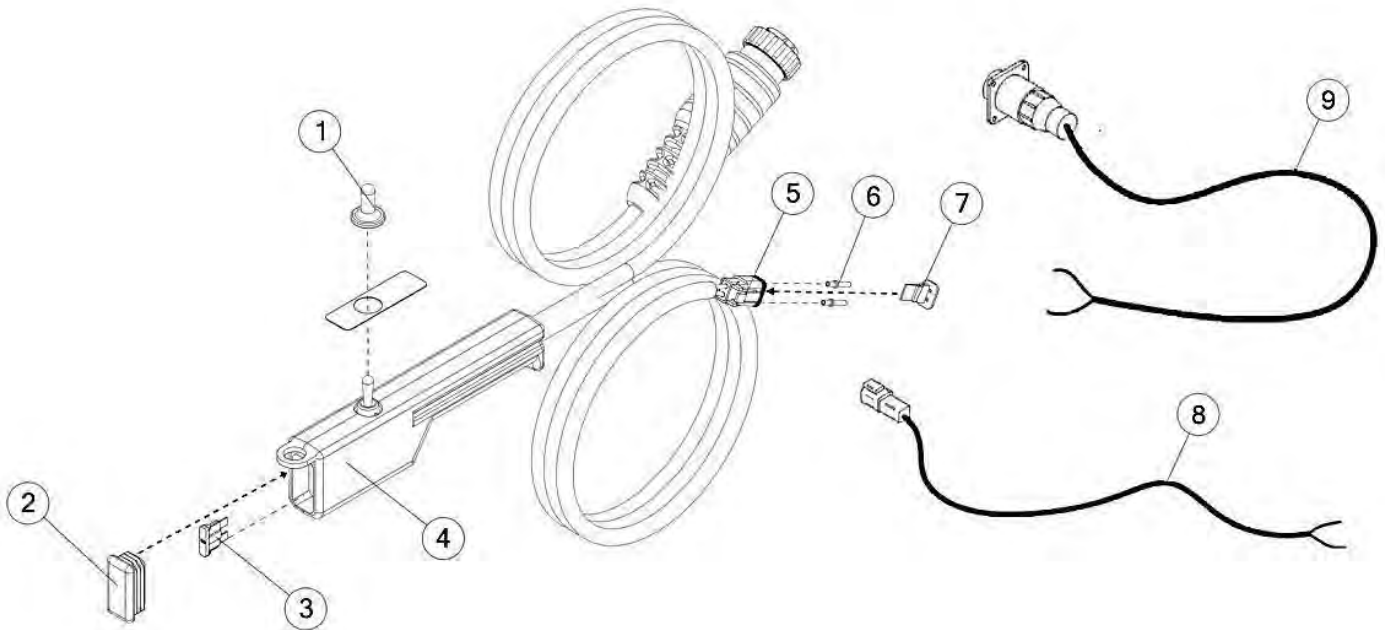

<u>ITEM</u>	<u>QTY</u>	<u>PART #</u>	<u>DESCRIPTION</u>
1	1	16SV235	SWITCH BOOTS
2	1	61564	CAP
3	1	61597	FUSE, BLADE, 5AMP
4	1	63365	HAND CONTROLLER (ON-OFF-ON)
5	1	58790	DEUTSCH 2 PIN PLUG
6	2	56760	DEUTSCH SOCKET, SOLID, 14-16 GA.
7	1	58793	LOCKING WEDGE FOR DT06-2S CONNECTOR
8	1	56N134	SPREADER CONTROL CORD
9	1	16SV269	TRACTOR CONTROL CABLE



**H&S Manufacturing products are approved for the
FEMA SEAL OF QUALITY**

**P.O. BOX 768, MARSHFIELD, WI 54449
(715) 387-3414 FAX (715) 384-5463
www.hsmfgco.com**