

H&S PARTS BOOK

2117 SPREADER



Revision #04

Starting Ser. #021PD17049

HSMFG0620

PART#72935

Manufactured By
H&S MANUFACTURING CO., INC.
2608 S. HUME AVE. MARSHFIELD, WI 54449
(715) 387-3414 FAX (715) 384-8736

CONTENTS

Instructions for Ordering Parts - About Improvements	1
Figure 1 - Beater and Pan Assembly	2-3
Figure 2 - Hub,Spindle & Box Parts	4-5
Figure 3 - Front Shields & Drive Assembly.	6-7
Figure 4 - Back Shields& Drive Assembly.	8-11
Figure 5 - Optional Hydraulic Endgate.	12-13
Figure 6 - Apron Chain Assembly.	14-15
Figure 7 - Optional Hydraulic Endgate Cylinder.	16-17
Figure 8 - Gearbox.	18-21
Figure 9 - PTO.	22-23
Figure 10 - Optional Top Beater.	24-25
Parts Notes.	26

INSTRUCTIONS FOR ORDERING PARTS

All service parts should be ordered through your authorized H&S dealer. He will be able to give you faster service if you will provide them with the following:

1. Model & Serial Number - Both can be located on the front PTO bearing support mount.
2. All references to left or right apply to the machine as viewed from the rear.
3. Parts should not be ordered from illustration only. Please order complete part number.
4. If your dealer has to order parts - give shipping instructions:

VIA truck - large pieces (please specify local truck lines)

VIA United Parcel Service (include full address)

H&S MFG. CO. INC.	
MARSHFIELD, WIS.	
MOD. NO.	<input type="text"/>
SER. NO.	<input type="text"/>
DESCR.	<input type="text"/>

PLEASE RECORD NUMBERS FOR YOUR UNIT FOR QUICK REFERENCE

ABOUT IMPROVEMENTS

H&S IS CONTINUALLY STRIVING TO IMPROVE IT'S PRODUCTS

We must therefore, reserve the right to make improvements or changes whenever it becomes practical to do so, without incurring any obligation to make changes or additions to the equipment previously sold.

FIGURE 1 BEATER AND PAN ASSEMBLY

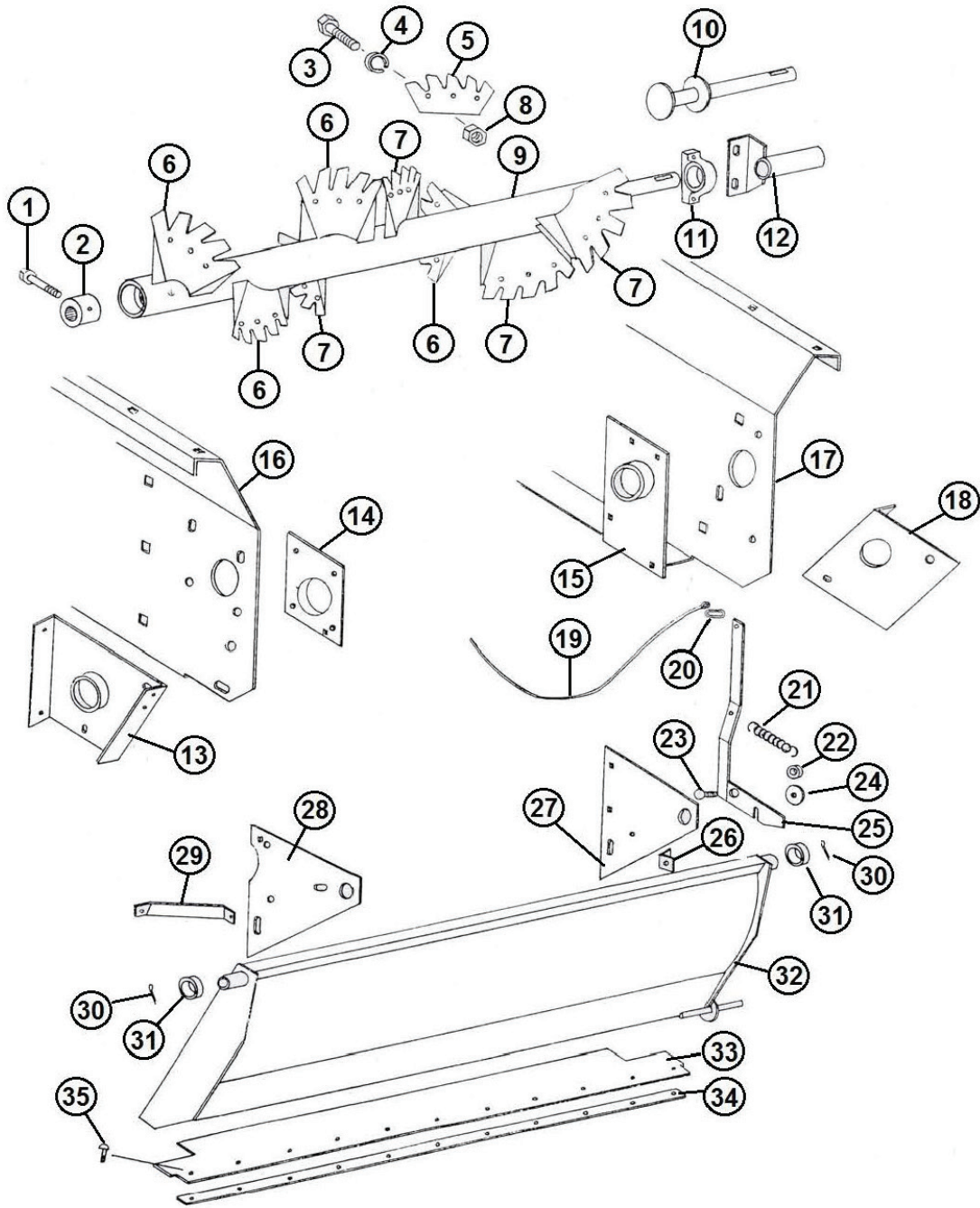

FIGURE 1

BEATER AND PAN ASSEMBLY

<u>ITEM</u>	<u>QTY</u>	<u>PART#</u>	<u>DESCRIPTION</u>
1	1	YBHH10130	BOLT, 5/16 X 5 G5
2	1	23N2	SPLINED BEATER INSERT
3	24	YBHH16045	BOLT, 1/2 X 1-1/4 G5
4	24	YWLO16005	WASHER, LOCK, 1/2
5	8	17G2	REPLACEMENT BEATER COMB
6	4	17G3	BEATER BLADE LH
7	4	17G4	BEATER BLADE RH
8	24	YNL16005	NUT HEX, TOP LOCK, 1/2
9	4	17G5	BEATER
10	4	17G6	BEATER STUB SHAFT
11	4	17G7	PILLOW BLOCK BEARING
12	4	17G8	STUB SHAFT SHIELD
13	1	17G9	DRIVE SHAFT MOUNT LH
14	1	17G10	ANTI-WRAP GUARD LH
15	1	17G11	ANTI-WRAP GUARD RH
16	1	17G12	SIDE PANEL LH
17	1	17G13	SIDE PANEL RH
18	1	17G14	DRIVE SHAFT MOUNT RH
19	1	17G15	PAN TRIP ROPE
20	1	R31	CLIP
21	1	R27	SPRING
22	1	23N23	SPACER
23	1	YBCR16010	BOLT CARR, 1/2 X 1-1/2 G5
24	1	YWFL16005	WASHER FLAT, 1/2
25	1	17G16	PAN TRIP LEVER
26	1	R26	ANGLE
27	1	17G17	PAN SUPPORT RH
28	1	17G18	PAN SUPPORT LH
29	1	17G19	PAN BRACE
30	2	YPCT06020	COTTER PIN, 3/16 X 2
31	2	F112	SPACER
32	1	17G20	PAN
33	1	17G21	PAN RUBBER FLAP
34	1	17G22	PAN STRAP
35	11	YBCR08010	BOLT CARRIAGE, 1/4 X 1-1/2

FIGURE 2 HUB, SPINDLE & BOX PARTS

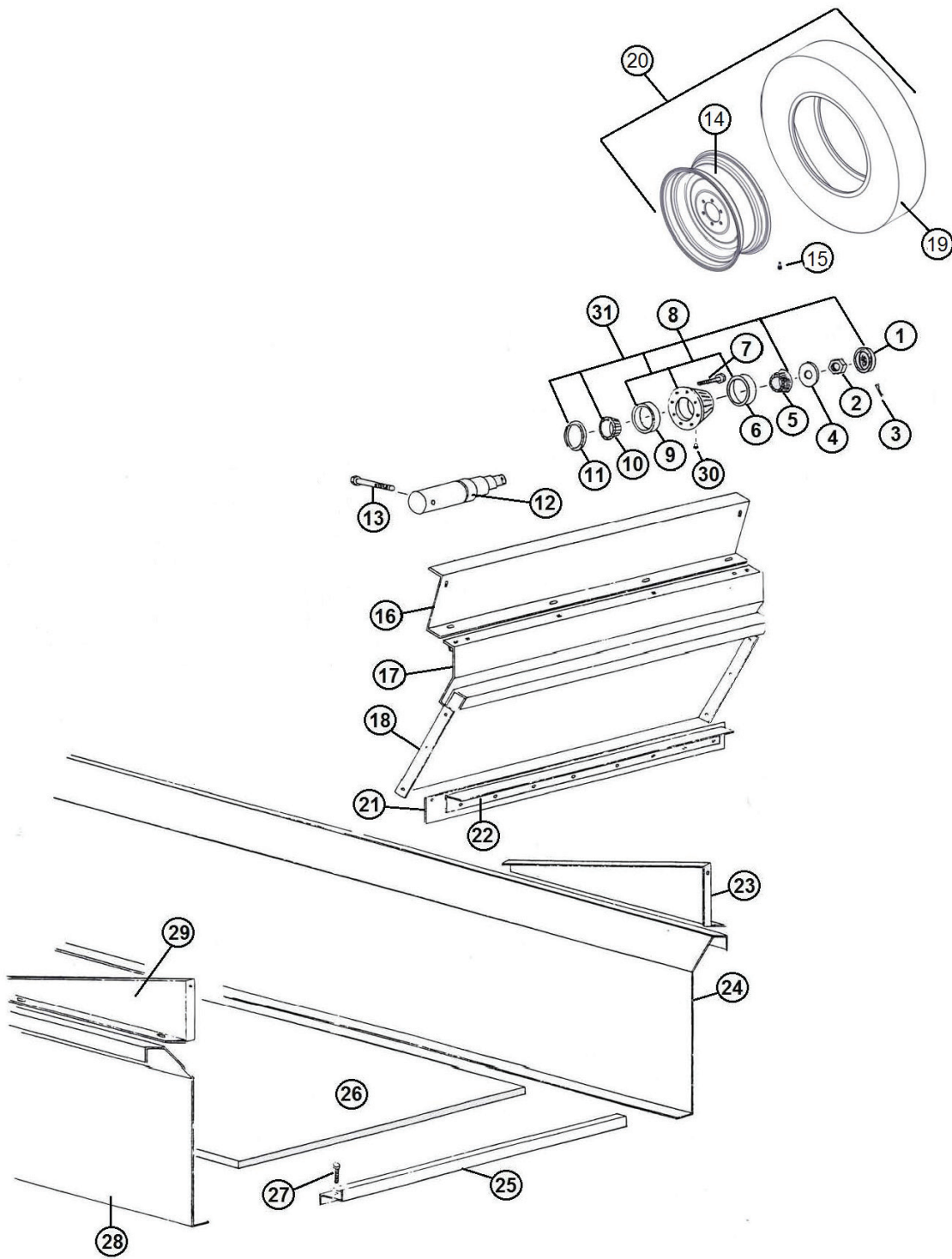

FIGURE 2

HUB, SPINDLE & BOX PARTS

<u>ITEM</u>	<u>QTY</u>	<u>PART#</u>	<u>DESCRIPTION</u>
1	2	17G144	HUB CAP
2	2	YNSL28005	NUT HEX, 7/8 G2
3	2	YPCT05020	COTTER PIN, 5/32 X 1-3/4
4	2	YWFL28005	WASHER FLAT, 7/8
5	2	17G145	BEARING
6	2	17G146	OUTER RACE
7	12	YBWL16005	BOLT WHEEL, 1/2-20 X 1 G5
8	2	75974	HUB ASSEMBLY
9	2	17G149	INNER RACE
10	2	17G150	INNER BEARING
11	2	17G151	GREASE SEAL
12	1	17G152	SPINDLE RH
*	1	17G153	SPINDLE LH
13	2	YBHH16130	BOLT HEX, 1/2 X 4, G5
14	2	55621	WHEEL, 22.5 X 8.25
15	2	72438	VALVE STEM, 1-1/2
16	1	17G26	FRONT SPLASH
17	1	17G27	FRONT FLARE
18	1	17G28	FRONT PANEL
19	2	UR19	TIRE, 295/75R22.5
20	2	69974	WHEEL, 22.5 X 8.25
21	1	17G30	FRONT RUBBER
22	1	17G31	ANGLE FOR RUBBER
23	1	17G32	SPLASH GUARD SIDE LH
24	1	17G12	SIDE PANEL LH
25	3	17G33	FRONT POLY FLOOR HOLD DOWN
26	1	17G158	POLY PLYWOOD
27	1	YBCR12015	BOLT CARR, 3/8 X 1-1/2, G5
28	1	17G13	SIDE PANEL RH
29	1	17G36	SPLASH GUARD SIDE RH
30	2	54595	ZERK, 1/8-27 NPT
31	2	17G148	HUB ASSEMBLY

***MEANS NOT SHOWN**

FIGURE 3 FRONT SHIELDS & DRIVE ASSEMBLY

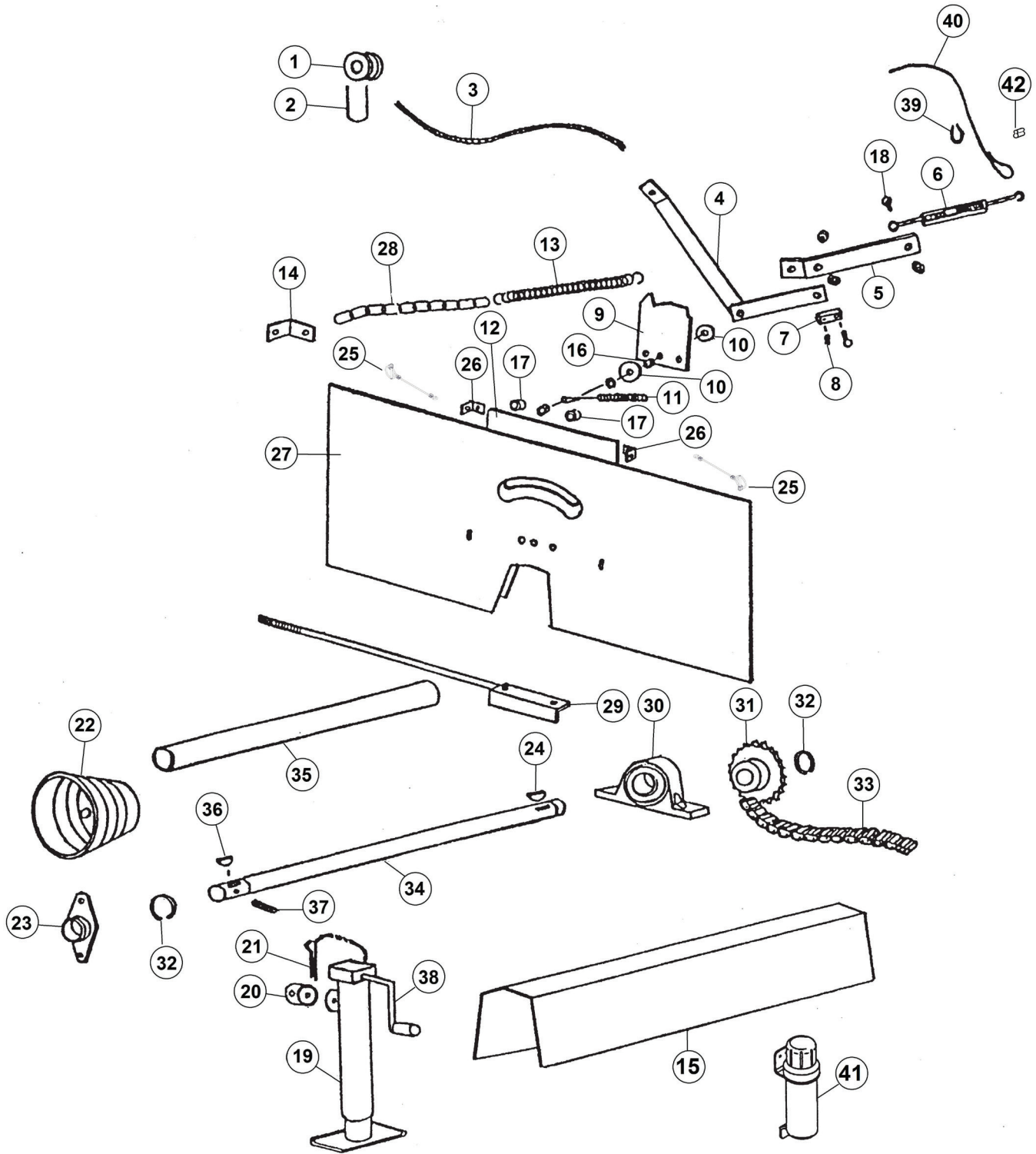

FIGURE 3

FRONT SHIELDS & DRIVE ASSEMBLY

<u>ITEM</u>	<u>QTY</u>	<u>PART#</u>	<u>DESCRIPTION</u>
1	1	F33	CABLE GUIDE
2	1	YBPU08005	PIPE U BOLT
3	1	23N183	ROPE
4	1	23N280	SHIFT LEVER
5	1	23N281	PIVOT LINK
6	1	F84	TURNBUCKLE
7	1	23N282	SHIFTER DOG
8	2	G89	GREASE ZERK
9	1	23N283	STOP BRACKET
10	2	YWCU12005	WASHER,
11	1	23N284	SHIFTER DOG SPRING
12	1	17G172	FRONT PANEL
13	1	10R14	SPRING
14	1	17G177	SPRING MOUNT ANGLE
15	1	17G157	FRONT SHAFT SHIELD
16	2	23N297	TUBE
17	2	ST81	SPACER
18	1	YBCR12010	BOLT CARR, 3/8 X 1 G5
19	1	12N116	JACK
20	1	12N121	JACK MOUNT
21	1	12N117	JACK PIN
22	1	17G45	PTO SHIELD
23	1	12N29	BEARING
24	1	5B9	WOODRUFF KEY
25	2	S122	LYNCH PIN, 1/4 X 1-1/2
26	2	R26	SHIELD BRACKET
27	1	17G173	FRONT POLY SHIELD
28	1	76054	CHAIN
29	1	17G48	TIGHTENER ROD
30	1	17G7	PILLOW BLOCK BEARING
31	1	23N70	SPROCKET
32	2	F73	SNAP RING
33	1	17G49	#60 CHAIN 116 PITCHES
34	1	17G50	FRONT SHAFT
35	1	17G179	FRONT SHAFT PVC GUARD
36	1	5B10	WOODRUFF KEY
37	1	YPEX10020	EXPANSION PIN, 5/16 X 2-1/4
38	1	12N12	HANDLE
39	1	ES14	THIMBLE
40	1	17G174	CABLE
41	1	S522	MANUAL HOLDER
42	1	71279	SLEEVE

FIGURE 4 BACK SHIELDS & DRIVE ASSEMBLY

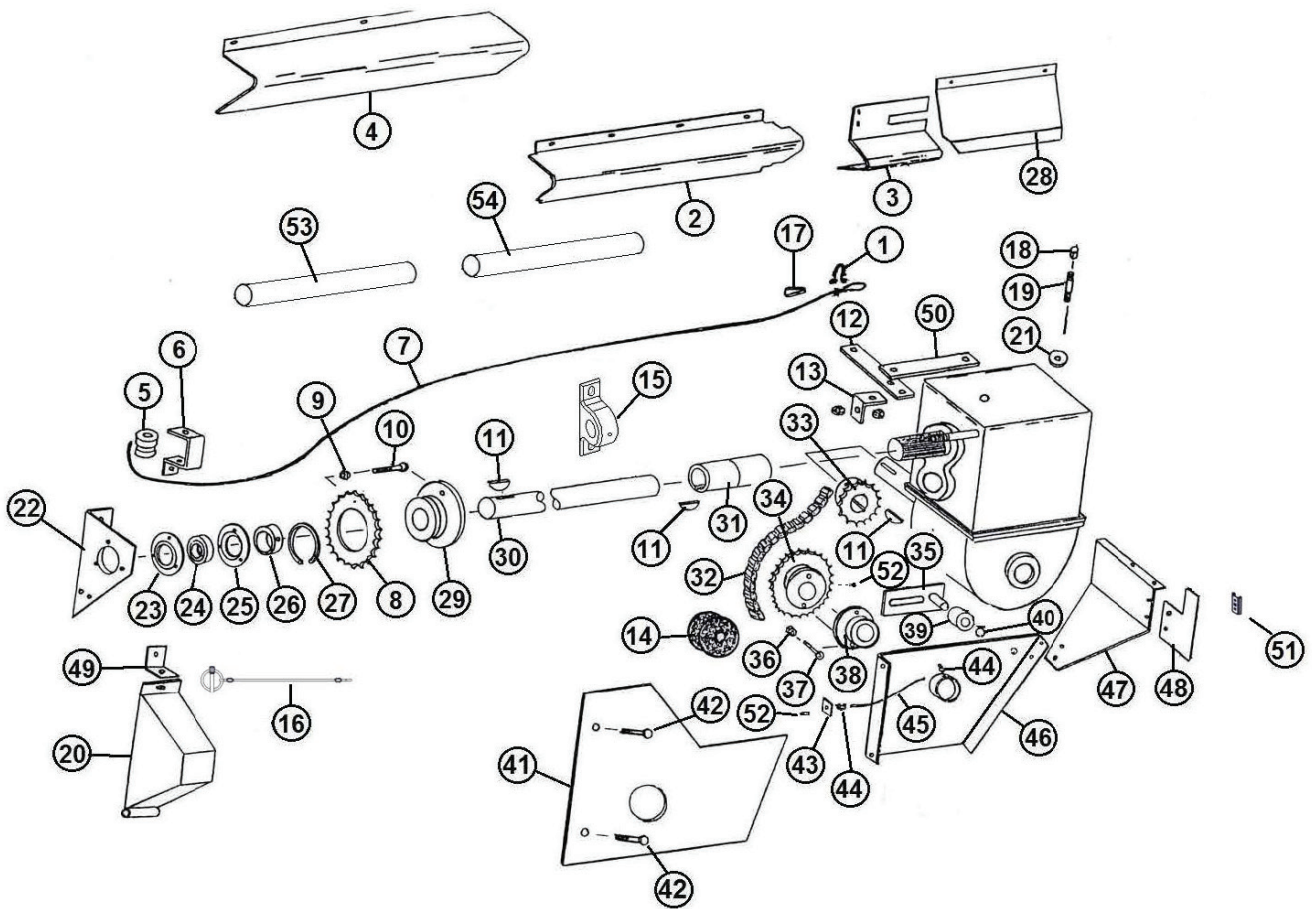

FIGURE 4

BACK SHIELDS & DRIVE ASSEMBLY

<u>ITEM</u>	<u>QTY</u>	<u>PART#</u>	<u>DESCRIPTION</u>
1	1	BFR220	CABLE CLAMP
2	1	17G52	BACK SIDE SHIELD
3	1	17G175	COUPLER SHIELD
4	1	17G54	FRONT SIDE SHIELD
5	1	F33	SIDE CABLE GUIDE
6	1	17G55	ROPE GUIDE BRACKET
7	1	17G40	CABLE
8	1	23N191	30T SPROCKET
9	1	YNTL10005	NUT HEX, TOP LOCK, 5/16
10	1	YBHH10030	BOLT, 5/16 X 1-1/2 G5
11	3	5B9	WOODRUFF KEY
12	1	23N290	SHIFTER ROD LEVER SHIFTER
13	1	23N291	ROD ANGLE
14	1	23N258	CHAIN OILER
15	1	12N36	COMP. BEARING ASSM.
16	1	S122	LANYARD, CLIP PIN CABLE
17	1	ES14	LOOP
18	1	17G58	VENT CAP
19	1	23N288	PIPE NIPPLE
20	1	17G76	SHIELD
21	1	17G61	WASHER
22	1	17G62	BEARING PLATE
23	1	F14	BEARING FLANGE
24	1	12N122	BEARING WITH LOCK COLLAR
25	1	F114A	FLANGE

FIGURE 4 BACK SHIELDS & DRIVE ASSEMBLY

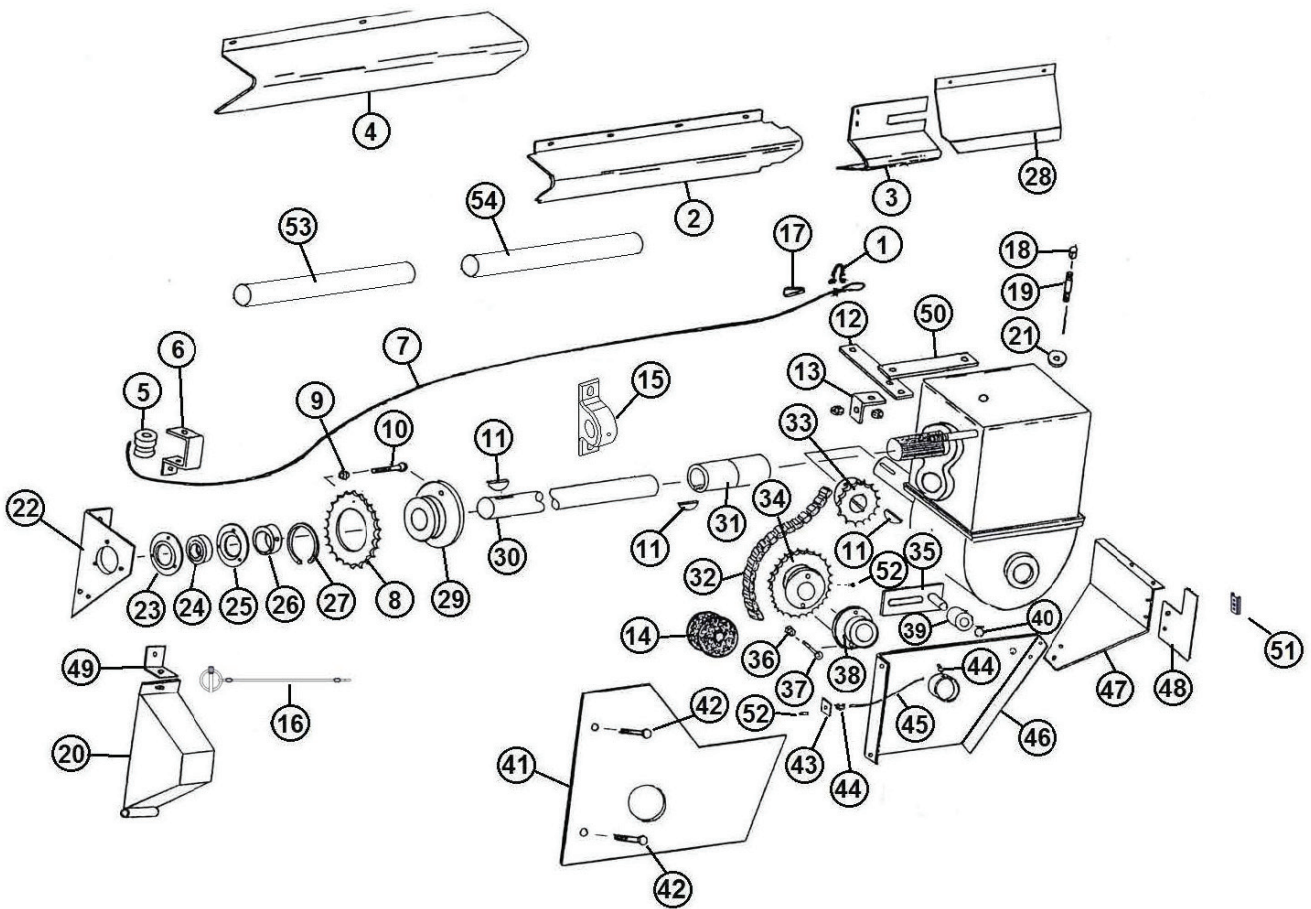

FIGURE 4

BACK SHIELDS & DRIVE ASSEMBLY

<u>ITEM</u>	<u>QTY</u>	<u>PART#</u>	<u>DESCRIPTION</u>
26	1	F16	LOCK COLLAR
27	1	23N189	SNAP RING
28	1	17G176	SHIFTER SHIELD
29	1	23N190	SHEAR HUB
30	1	17G64	SIDE SHAFT
31	1	17G65	COUPLER
32	1	17G66	#60 CHAIN 53 PITCHES
33	1	17G67	WORM GEAR SPROCKET
34	1	17G68	SHEAR HUB SPROCKET
35	1	17G69	CHAIN TIGHTENER BRACKET
*	1	17G70	COMPLETE TIGHTENER
36	1	YNTL10005	NUT HEX, TOP LOCK, 5/16
37	1	YBHH10030	BOLT, 5/16 X 1-1/2 G5
38	1	17G71	SHEAR HUB
39	1	23N238	CHAIN TIGHTENER ROLLER
40	1	10R32	SNAP RING
41	1	17G72	BACK POLY SHIELD
42	2	12V3	5/16 SELF-TAPPING BOLTS
43	1	16V9	GREASE ZERK BLOCK
44	2	S47	GREASE LINE FITTING
45	1	17G73	GREASE LINE
46	1	17G9	LH DRIVE SHAFT MOUNT
47	1	17G74	GEARBOX BRACE
48	1	17G75	SMV BRACKET
49	1	23N242	SHIELD ANGLE
50	1	23N289	SHIFTER ROD LEVER FOLCRUM
51	1	F97	SMV BRACKET
52	1	G89	STRAIGHT ZERK
53	1	32058	#1 SIDE SHAFT GUARD - FRONT
54	1	32057	#2 SIDE SHAFT GUARD - BACK

*MEANS NOT SHOWN

FIGURE 5 **OPTIONAL HYDRAULIC ENDGATE**

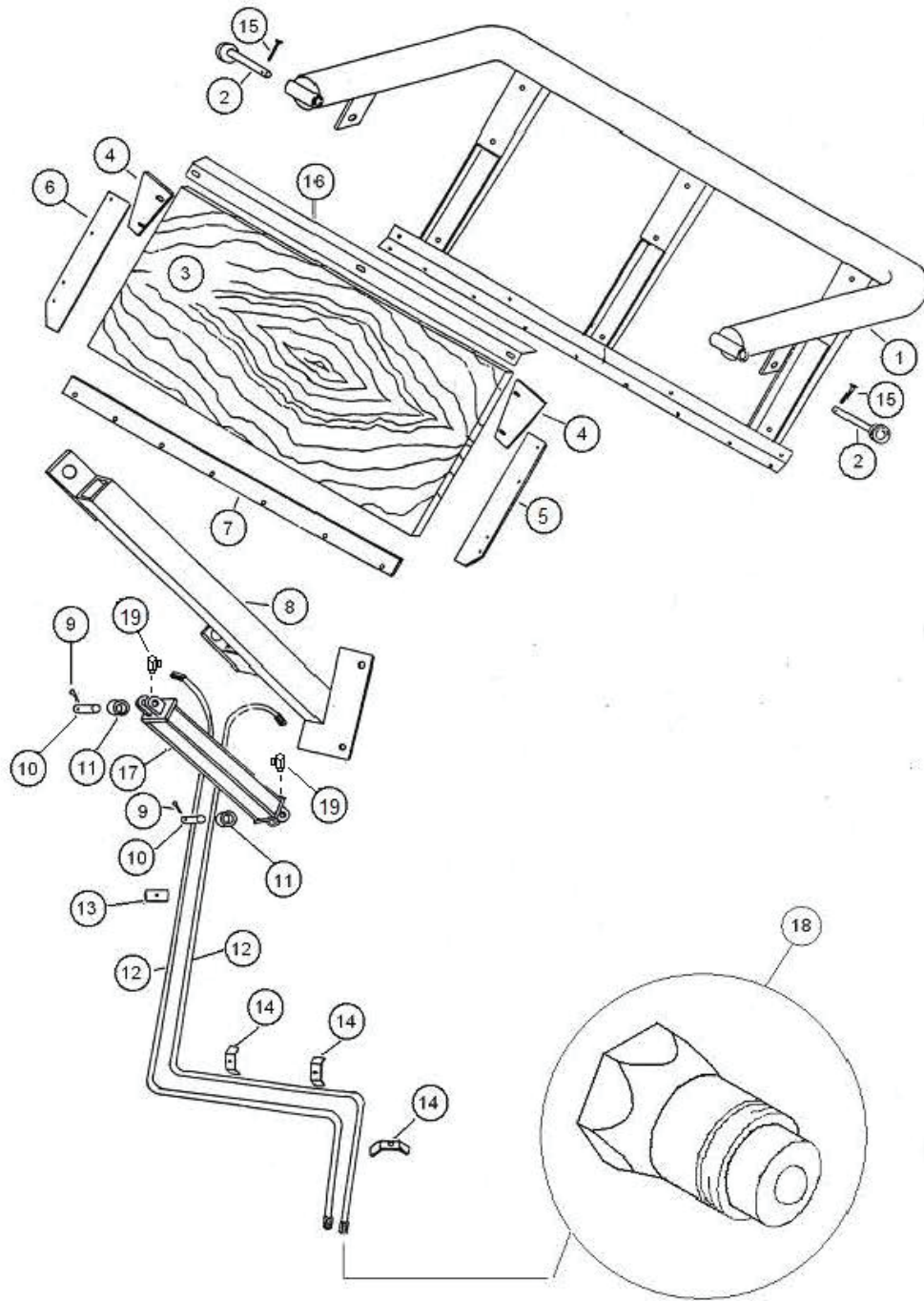

FIGURE 5

OPTIONAL HYDRAULIC ENDGATE

<u>ITEM</u>	<u>QTY</u>	<u>PART#</u>	<u>DESCRIPTION</u>
1	1	17G77	TAILGATE FRAME
2	2	17G78	TAILGATE PIN
3	1	17G79	TAILGATE PLYWOOD
4	2	17G80	TAILGATE CORNER
5	1	17G81	LH SIDE RUBBER
6	1	17G82	RH SIDE RUBBER
7	1	17G83	BOTTOM RUBBER
8	1	17G84	TAILGATE MOUNTING TUBE
9	2	YPCT07005	COTTER PIN, 7/32 X 2
10	2	23N107	PIN
11	2	K132	SPACER
12	2	23N302	HOSE, 22
13	1	17G87	HOSE BRACKET
14	3	23N67	HOSE BRACKET
15	2	YBHH10080	BOLT, 5/16 X 2-1/2 G5
16	1	17G160	TAILGATE PLYWOOD HOLD DOWN
17	1	56015	HYDRAULIC CYLINDER
18	2	DWM205	MALE QUICK COUPLER
19	2	DWM110	SWIVEL

FIGURE 6 APRON CHAIN ASSEMBLY

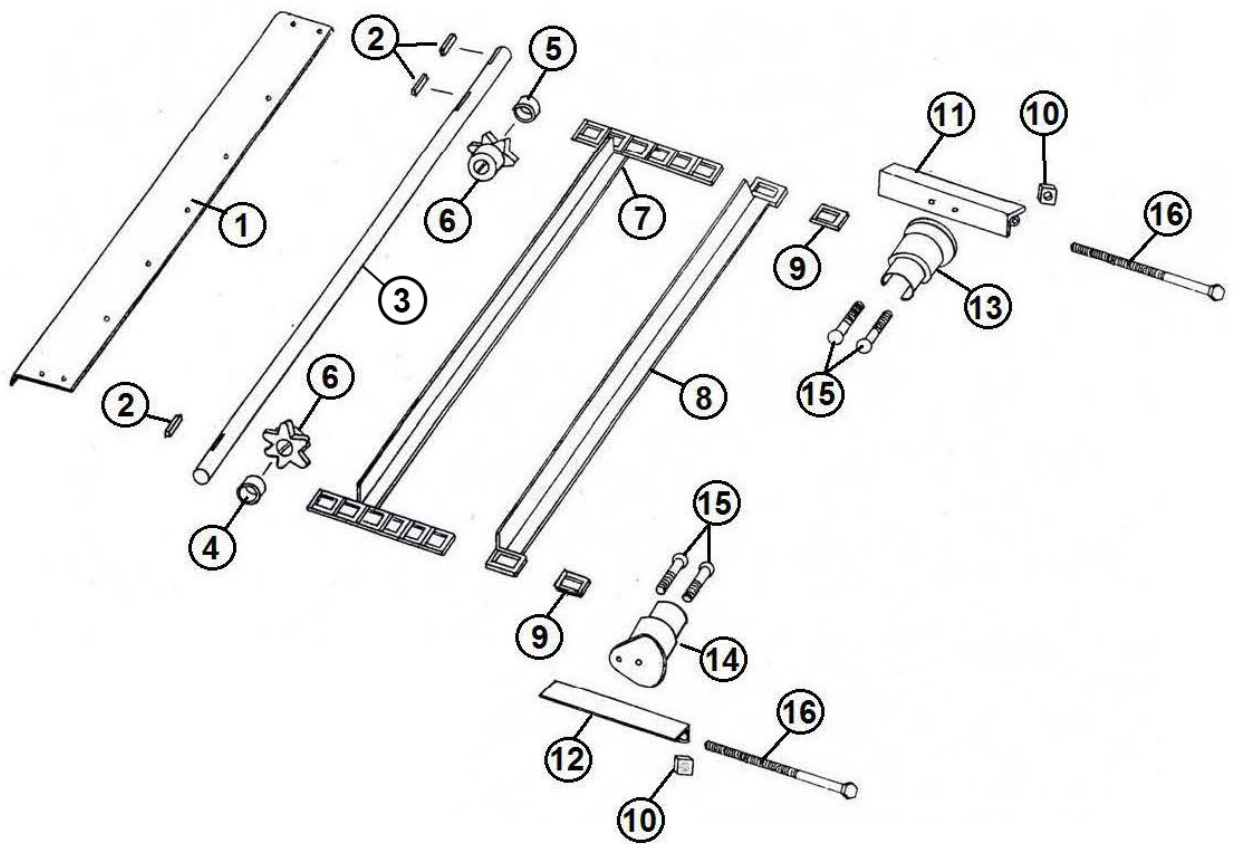

FIGURE 6
APRON CHAIN ASSEMBLY

<u>ITEM</u>	<u>QTY</u>	<u>PART#</u>	<u>DESCRIPTION</u>
1	1	17G88	DRIVE SHAFT SHIELD
2	3	A32	SQUARE KEY
3	1	17G89	DRIVE SHAFT
4	1	17G90	SPACER
5	5	17G91	SPACER
6	2	23N122	SPROCKET
7	7	17G92	APRON CHAIN
8	1	17G93	SLAT W/ ATT. LINKS
9	2	S55	T-ROD STANDARD LINK
10	2	A20	SQUARE NUT
11	1	17G94	CHAIN SLIDE ANGLE LH
12	1	17G95	CHAIN SLIDE ANGLE RH
13	1	17G96	T-ROD SLIDE LH
14	1	17G97	T-ROD SLIDE RH
15	4	YBCR16030	BOLT CARR, 1/2 X 2-1/2 G5
16	2	YBHH16190	BOLT, 1/2 X 9-1/2 G5

FIGURE 7
OPTIONAL HYDRAULIC ENDGATE CYLINDER

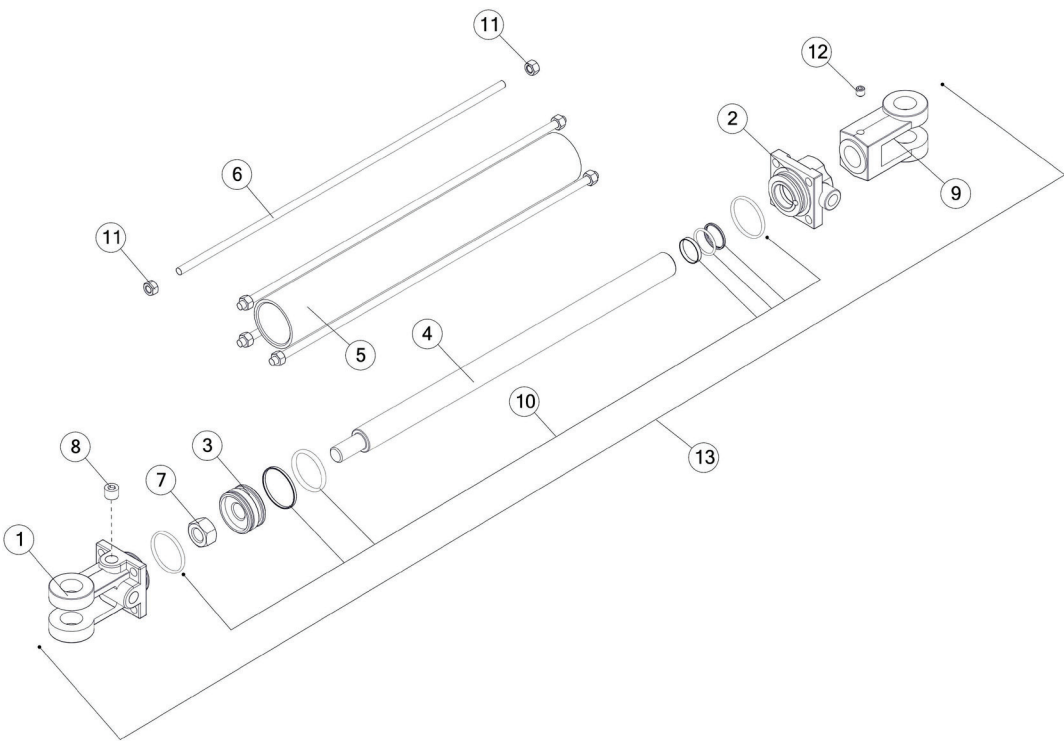

FIGURE 7
OPTIONAL HYDRAULIC ENDGATE CYLINDER

<u>ITEM</u>	<u>QTY</u>	<u>PART#</u>	<u>DESCRIPTION</u>
1	1	23N142A	CLEVIS CAP
2	1	56174	ROD CAP
3	1	56180	PISTON
4	1	23N145A	ROD
5	1	23N146	CYL. TUBE
6	4	23N147	SHAFT
7	1	23N148	PISTON NUT
8	1	23N149	PLUG
9	1	23N150A	ROD CLEVIS
10	1	56187	SEAL KIT
11	8	YNHX12006	NUT HEX, 3/8 G2
12	1	YSSO12015	SET SCREW
13	1	56015	HYDRAULIC CYLINDER

FIGURE 8 GEARBOX

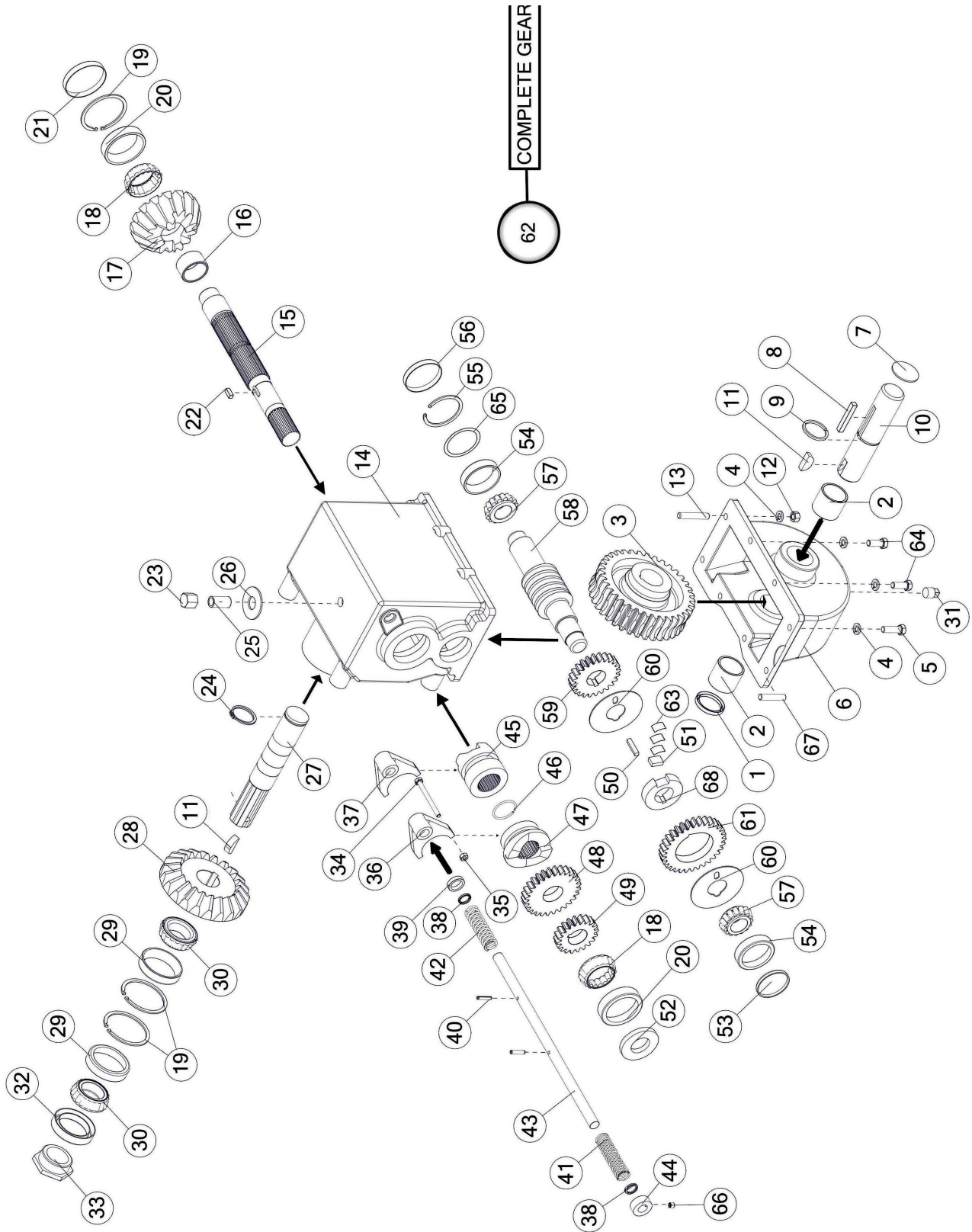

FIGURE 8 GEARBOX

<u>ITEM</u>	<u>QTY</u>	<u>PART#</u>	<u>DESCRIPTION</u>
1	1	17G133	SEAL
2	2	17G134	BUSHING
3	1	17G137	WORM GEAR
4	8	YWLO12005	WASHER LOCK, 3/8
5	2	YBHH12035	BOLT HEX, 3/8 X 1-1/4 G5
6	1	17G107	LOWER CAST
7	1	17G139	CAP
8	1	17G132	KEY
9	1	17G135	SNAP RING
10	1	17G136	SHAFT
11	2	5B9	KEY
12	2	YNHX12005	HEX NUT, 3/8 G2
13	2	17G140	STUD
14	1	17G99	UPPER CAST
15	1	17G108A	SHAFT
16	1	17G111	BUSHING
17	1	17G110	GEAR
18	2	G18	BEARING
19	3	G55	SNAP RING
20	2	18VB25	BEARING
21	1	G68	CAP
22	1	17G116	KEY
23	1	17G58	VENT CAP
24	1	12V62	SNAP RING
25	1	23N288	PIPE NIPPLE
26	1	YWFL24005	WASHER FLAT, 3/4 IN USS
27	1	17G104	SHAFT
28	1	17G101	BEVEL, 22T
29	2	17G102	RACE
30	2	17G103	BEARING
31	1	G65	PLUG PIPE, 3/8
32	1	17G105	SEAL
33	1	17G106	NUT HEX
34	1	YBHH08090	BOLT, 1/4 X 3 G2
35	1	YNHX08007	NUT HEX, 1/4-20 G5

FIGURE 8 GEARBOX

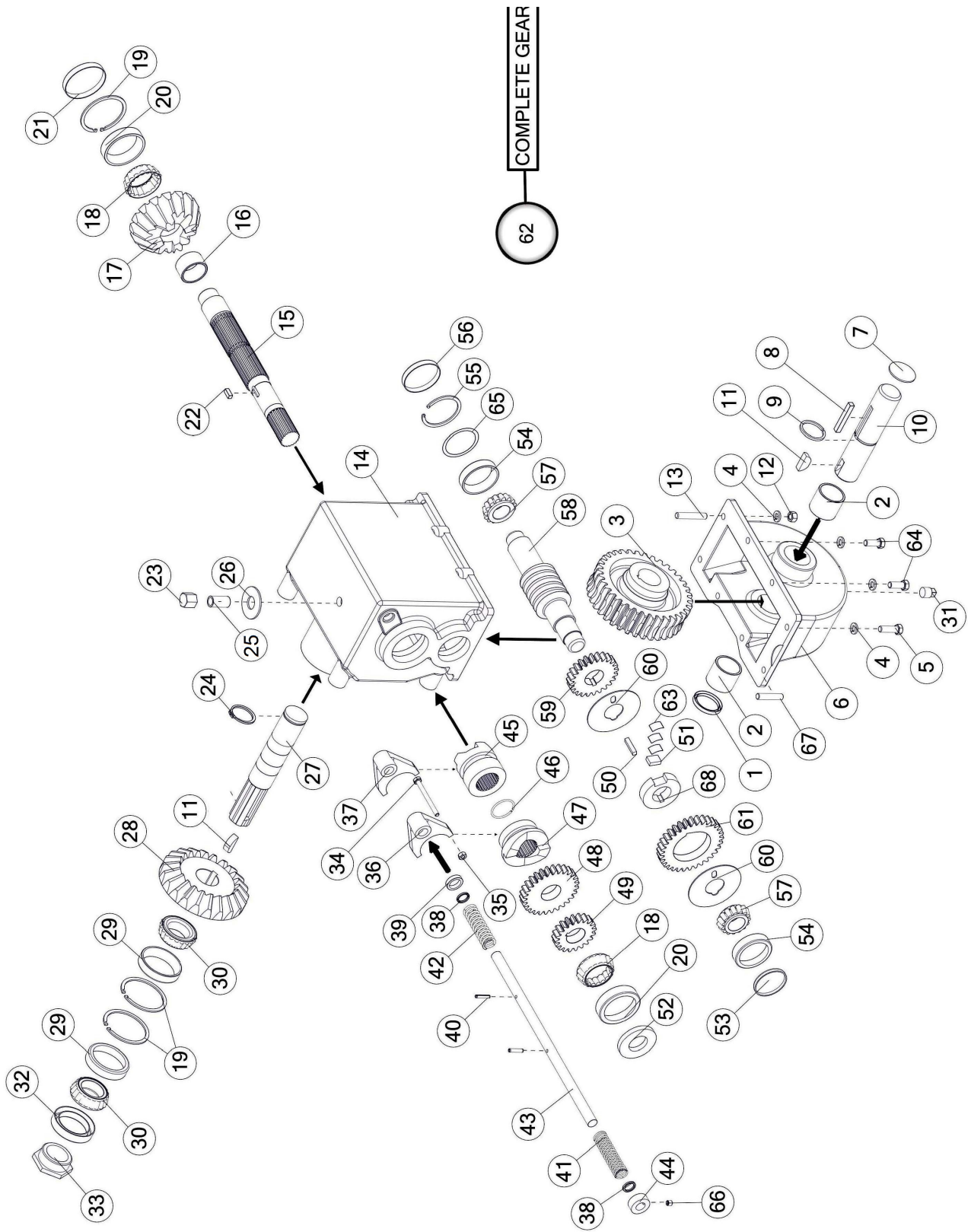

FIGURE 8 GEARBOX

<u>ITEM</u>	<u>QTY</u>	<u>PART#</u>	<u>DESCRIPTION</u>
36	1	17G125	YOKE, SHIFTER, HIGH SPEED
37	1	17G129	YOKE, SHIFTER, BEATER
38	2	17G121	SEAL
39	1	17G122	TUBE
40	2	17G123	PIN
41	1	17G128	SPRING
42	1	17G130	SPRING
43	1	17G131	SHAFT
44	1	17G171	COLLAR
45	1	17G109	BEATER CLUTCH
46	1	17G169A	SNAP RING
47	1	17G119	HIGH SPEED CLUTCH,
48	1	17G118	GEAR
49	1	17G115	LOW SPEED, 2 SPEED GEAR BOX
50	1	S135	KEY
51	1	17G124	CLUTCH DOG
52	1	S136	SEAL
53	1	17G100	CAP
54	2	3G18	BEARING
55	1	3G19	SNAP RING
56	1	G90	CAP
57	2	L3G24	BEARING
58	1	17G120	SHAFT
59	1	17G117	GEAR
60	2	17G112	WASHER FLAT
61	1	17G113	LOW SPEED GEAR, 2 SPEED GEARBOX
62	1	17G142	ASSEMBLY, 2 SPEED GEARBOX
63	3	17G126	SPRING
64	4	YBHH12010	BOLT HEX, 3/8 X 1 G5
65	1	G92	SHIM
66	1	YSKP10015	SET SCREW
67	1	17G138	STUD
68	1	17G114	CLUTCH, LOW SPEED, 2 SPEED GEARBOX

FIGURE 9 PTO ASSEMBLY

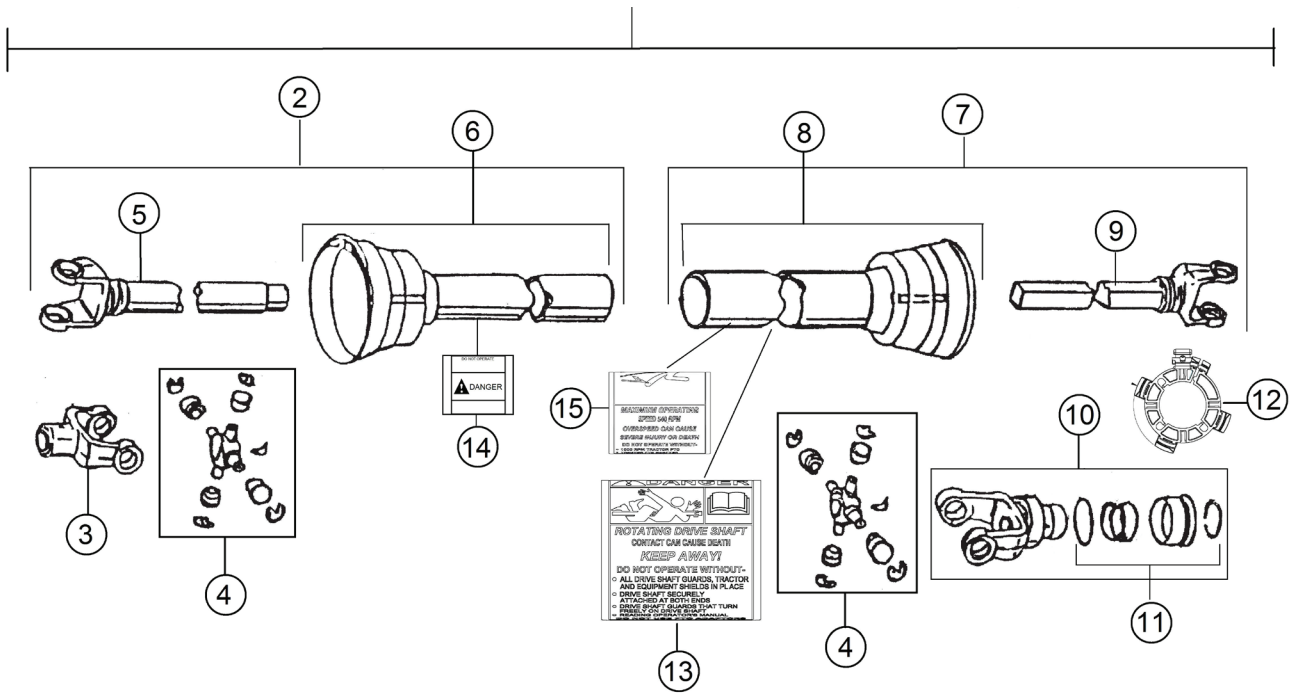

FIGURE 9 PTO ASSEMBLY

<u>ITEM</u>	<u>QTY</u>	<u>PART#</u>	<u>DESCRIPTION</u>
1	1	23N152	COMPLETE PTO ASS'Y W/SHIELDS
2	1	23N153	MACHINE HALF PTO W/SHIELD
3	1	G1R35	YOKE 1-1/4
4	2	14NW	14R CROSS & BEARING KIT
5	1	23N155	YOKE AND TUBE
6	1	23N156	INNER GUARD
7	1	23N157	TRACTOR HALF PTO W/SHIELD
8	1	23N158	OUTER GUARD
9	1	23N159	YOKE AND SHAFT
10	1	23N162	PTO LOCK YOKE ASSEMBLY
11	1	S225	SPRING-LOK REPAIR KIT
12	1	16SV181	NYLON REPAIR
13	1	16SV283	DECAL, PTO SAFETY
14	1	16SV388	DECAL, PTO SAFETY INNER GUARD
15	1	16SV384	SAFETY SIGN 540 RPM
*	1	S402	ADMA SAFETY MANUAL

*MEANS NOT SHOWN

FIGURE 10 OPTIONAL TOP BEATER

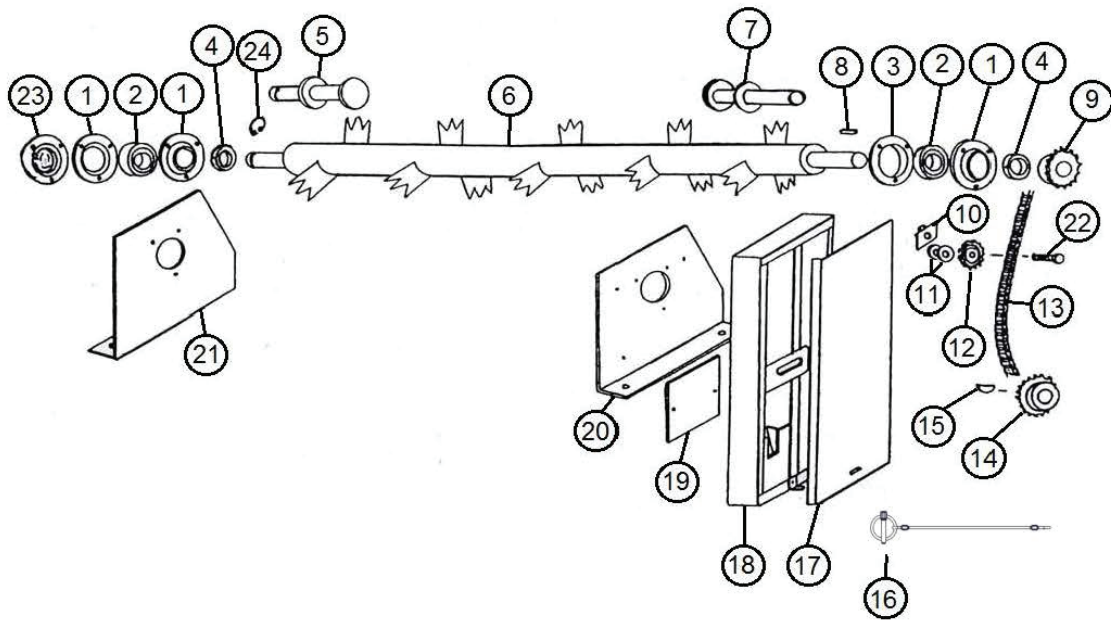

FIGURE 10

OPTIONAL TOP BEATER

<u>ITEM</u>	<u>QTY</u>	<u>PART#</u>	<u>DESCRIPTION</u>
1	2	F114A	FLANGE, 1-1/4 W/45 DEG. ZERK
2	2	12N122	BEARING WITH LOCK COLLAR BEARING
3	1	F114	FLANGE
4	1	F16	LOCK COLLAR
5	1	23N164	STUB SHAFT LH
6	1	17G180	2ND BEATER
7	1	17G186	RH STUB SHAFT
8	1	G23B	SQUARE KEY
9	1	D18	SPROCKET
10	1	22G34	NUT BRACKET
11	1	YWFL16005	WASHER FLAT, 1/2
12	1	12N42	IDLER SPROCKET
13	1	22G35	#60 CHAIN 80 PITCHES
14	1	F13	SPROCKET 20T
15	1	5B9	WOODRUFF KEY
16	1	S122	LANYARD
17	1	22G36	COVER
18	1	17G181	SHIELD
19	1	22G38	SHIELD
20	1	17G182	PANEL RH
21	1	17G183	PANEL LH
22	1	YBHH16080	BOLT HEX, 1/2 X 2-1/2 G5
23	1	77318	BEARING FLANGE
24	1	F22	SNAP RING

CHANGE NOTES

1. Figure 2 - removed non-servicable parts

H&S MFG. CO.

products approved

for the

FEMA

SEAL OF QUALITY

